

## Engineering Instructions for Addressable multipurpose I/O unit 3361.

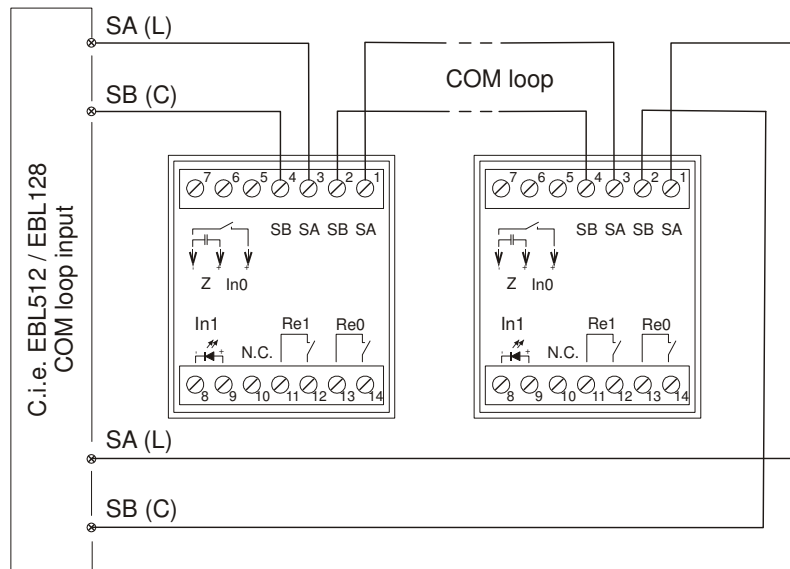

Figure 1. Connection of the COM loop.

### 1. Program the COM loop address

Program the COM loop address of the I/O unit with the 3314 address setting tool.

Note! The address has to be programmed before the I/O unit is connected to the COM loop.

### 2. Mounting of the I/O unit

Mount the I/O unit on the wall / in the ceiling. There are two mounting holes, c/c 60 mm, and diameter 3 mm. It can be DIN rail mounted with help of a DIN rail interface kit 3363.

When required, the 3361 unit can be mounted in a waterproof box 3362 (IP 66/67).

### 3. Wiring

Use single copper wire, 0.6 - 1.2 mm in diameter. Strip its coating by 10 mm and put it into the terminal respectively. Tighten the terminal screws firmly.

The wires from the c.i.e. "COM loop input" shall be connected to the SA and SB terminals respectively according to the figure 1. Connect the next unit or the wires going back to the c.i.e. "COM loop input" to the SA and SB terminals in the unit according to figure 1.

Connection examples are found on the next page.

### 4. Apply the protection cover

Cut out appropriate cable inlets in the protection cover. Push the protection cover in position.

## 5. Connection Examples

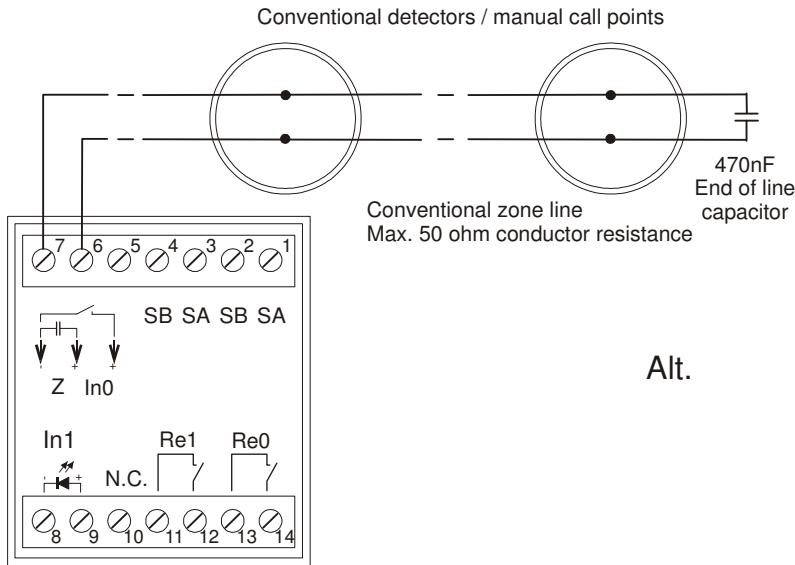

Figure 2. Monitored input used as zone line input.

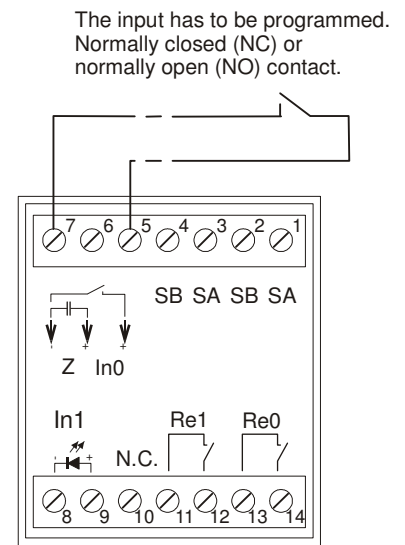

Figure 3. Monitored input used as general input

### Monitored input (two alternatives)

....used as zone line input (Z): Supplied end-of-line capacitor 470 nF to be mounted in the last unit on the line. Short circuit could activate fault or fire alarm (set via Win512 / Win128). This input is intended for conventional detectors / manual call points. Max. 50 Ohm conductor resistance.

....used as general input (In0): An input for a NC or NO contact (set via Win512 / Win128).

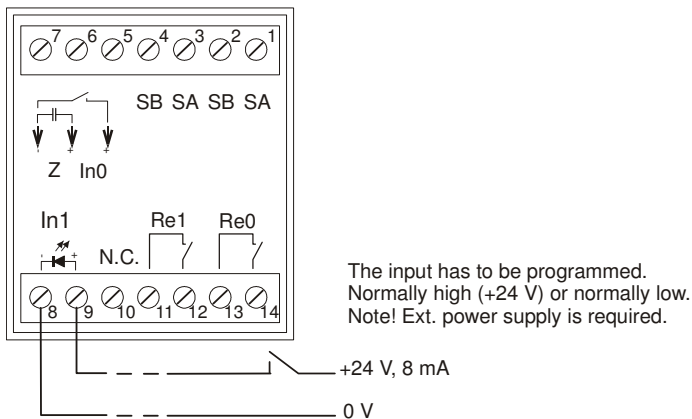

Figure 4. Isolated input

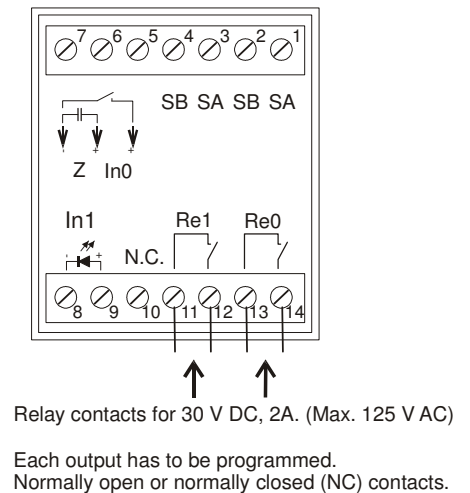

Figure 5. Programmable outputs

**Isolated input (In1):** An optocoupler input (external 24 V DC / 8 mA is required). Normally low or high (set via Win512 / Win128).

**Relay output (Re0):** NC or NO contacts (set via Win512 / Win128).

**Relay output (Re1):** NC or NO contacts (set via Win512 / Win128).

All technical features and data are subject to changes without notice, resulting from continuous development and improvement.

Engineering instructions	Date of issue	Revision / Date of revision
MEW00941	2007-07-02	