

Engineering Instructions for Addressable siren 3377.

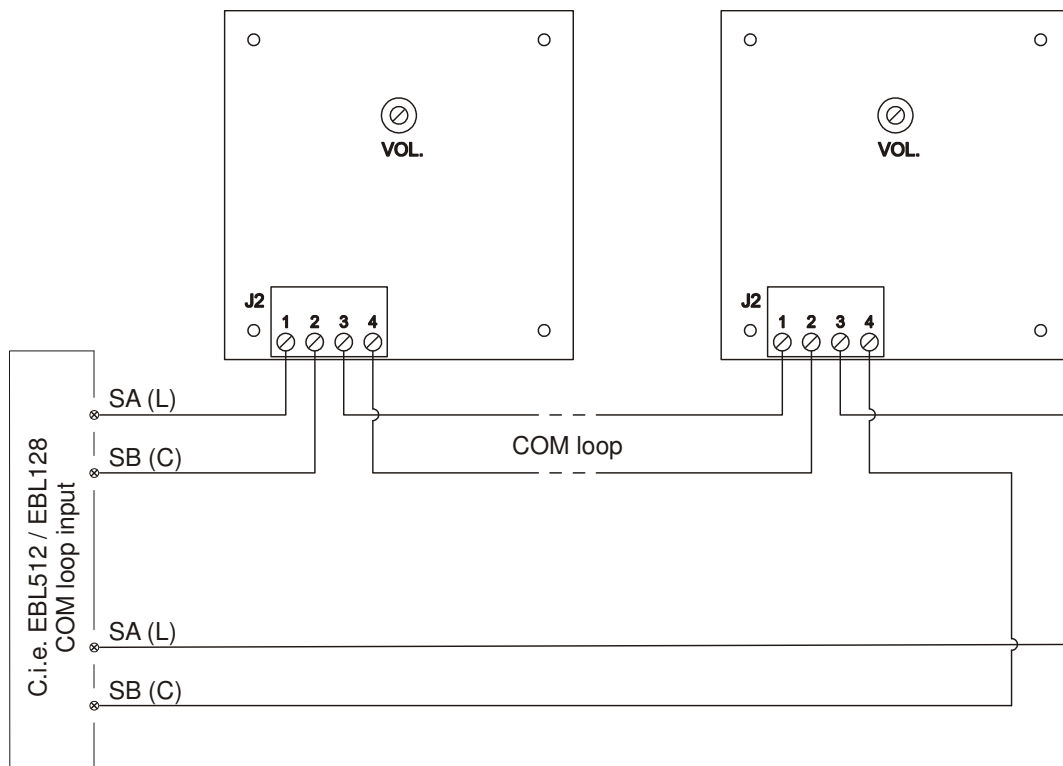

1. Mounting of the backbox

Remove the backbox by using the supplied key. Press the two “pins” on the key into the corresponding holes in the right side of the backbox to separate the siren element from the backbox.

Mount the backbox on the wall. There is provision for rear cable entry. In case of open wiring (surface mounted back box), cable holes can be drilled into the bottom of the back box – Max. diameter 20mm.

2. Program the COM loop address

Program the COM loop address of the addressable siren with the 3314 address setting tool. Remove the pluggable terminal and connect the 3314 address setting tool’s connection cable. Apply the terminal again.

Note! The address has to be programmed before the m.c.p. is connected to the COM loop.

3. Wiring

Use single copper wire, 0.6 - 1.2 mm in diameter. Strip its coating by 10 mm and put it into the terminal respectively. Tighten the terminal screws firmly, max. torque 0.4 Nm.

The wires from the c.i.e. "COM loop input" shall be connected to the SA and SB terminals respectively according to the figure.

Connect the next unit or the wires going back to the c.i.e. "COM loop input" to the SA and SB terminals in the unit according to the figure.

4. Adjusting the volume

After production the volume of the addressable siren is set to nearly maximum. The potentiometer to adjust the volume is marked “VOL.” in the figure. To reduce the volume turns the potentiometer anti-clockwise.

5. Plugging the siren element in the backbox

Put the siren element in position and push it onto the backbox.

Sound output

	Two-tone (Alternating)						Maximum volume					
	Horizontal orientation L[dB]						Vertical orientation L[dB]					
	15°	45°	75°	105°	135°	165°	15°	45°	75°	105°	135°	165°
12 V DC	79.2	84.7	89.5	89.6	83.2	79.4	77.8	83.6	87.6	89.9	84.9	81.6
28 V DC	82.4	90.0	95.5	94.9	87.3	84.2	81.2	88.4	93.4	93.2	87.3	84.0

	Two-tone (Alternating)						Minimum volume					
	Horizontal orientation L[dB]						Vertical orientation L[dB]					
	15°	45°	75°	105°	135°	165°	15°	45°	75°	105°	135°	165°
12 V DC	71.1	78.5	82.0	82.7	77.9	73.0	71.0	76.5	81.7	82.7	80.1	74.3
28 V DC	76.7	84.2	86.9	86.7	83.7	76.7	75.6	82.2	87.4	87.8	80.5	78.5

	Continuous						Maximum volume					
	Horizontal orientation L[dB]						Vertical orientation L[dB]					
	15°	45°	75°	105°	135°	165°	15°	45°	75°	105°	135°	165°
12 V DC	80.1	85.6	91.1	90.0	89.1	80.7	79.3	85.4	87.1	89.1	86.9	84.6
28 V DC	82.1	88.8	92.1	93.3	91.7	82.6	83.7	89.9	92.2	92.9	89.3	87.0

	Continuous						Minimum volume					
	Horizontal orientation L[dB]						Vertical orientation L[dB]					
	15°	45°	75°	105°	135°	165°	15°	45°	75°	105°	135°	165°
12 V DC	72.6	76.9	81.7	81.0	77.0	71.7	72.4	79.1	83.5	81.0	76.8	73.3
28 V DC	73.9	79.7	86.7	86.4	78.3	75.2	74.8	82.4	88.1	86.0	82.0	78.2

	Pulsed (Intermittent)						Maximum volume					
	Horizontal orientation L[dB]						Vertical orientation L[dB]					
	15°	45°	75°	105°	135°	165°	15°	45°	75°	105°	135°	165°
12 V DC	80.7	83.5	89.7	91.3	81.0	76.3	75.2	83.1	87.8	89.9	84.7	77.7
28 V DC	82.2	85.0	92.2	94.6	84.7	81.2	78.6	88.5	91.5	90.9	87.3	83.0

	Pulsed (Intermittent)						Minimum volume					
	Horizontal orientation L[dB]						Vertical orientation L[dB]					
	15°	45°	75°	105°	135°	165°	15°	45°	75°	105°	135°	165°
12 V DC	72.8	76.1	82.1	80.7	73.7	72.8	71.2	75.8	79.9	82.3	78.6	70.2
28 V DC	77.8	80.7	85.8	85.9	77.5	77.9	73.3	79.0	83.4	86.8	83.2	74.6

All technical features and data are subject to changes without notice, resulting from continuous development and improvement.

Engineering instructions	Date of issue	Revision / Date of revision
MEW00955	2007-07-11	2 / 2008-12-08