

5014

Batteriskap



Egenskaper

- › Metallskap beregnet på eksterne batterier
- › Designet for to 60-65 Ah batterier
- › Kabelinnføring på toppen av kabinettet
- › For veggmontasje

Generelt

- › Plass til to 12 V batterier

Ordrenummer

- › 5014 - Batteriskap for 60 Ah batterier

Relaterte produkter

- › 5000 - EBL512 G3
- › 5001 - EBL512 G3
- › 4466 - Ekstern strømforsyning

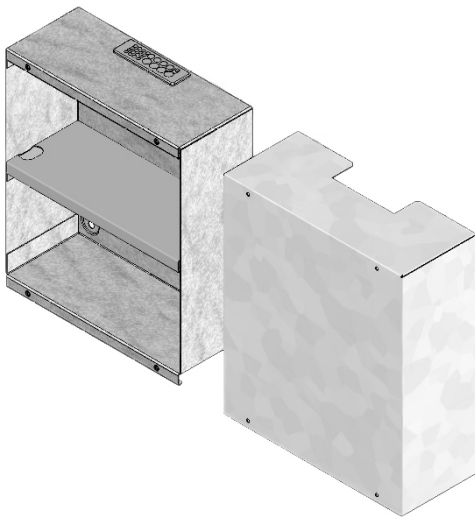

13 kg



420 x 487 x 175 mm



-5 TO +40 °C



<95%

