



# 2000

## CONTROL AND INDICATING EQUIPMENT EBLOne

Fire alarm solutions  
technical description

# Table of Contents

<b>1.</b>	<b>INTRODUCTION</b>	4
<b>2.</b>	<b>SAFETY INSTRUCTIONS</b>	5
2.1.	PERSONS	5
2.1.1.	ORDINARY PERSON	5
2.1.2.	INSTRUCTED PERSON	5
2.1.3.	SKILLED PERSON	5
2.2.	WARNINGS	6
<b>3.</b>	<b>GENERAL DESCRIPTION</b>	7
3.1.	OPTIONS	7
3.2.	TOUCH SCREEN	9
3.3.	ALARM PRESENTATION	9
3.4.	CONTROL PANEL	9
3.5.	USB	9
3.6.	MAIN BOARD	10
3.7.	CIE CHASSIS	11
3.8.	BATTERIES	12
3.9.	POWER SUPPLY	12
3.9.1.	DISCONNECT DEVICE	13
<b>4.</b>	<b>CONNECTIONS IN THE CIE</b>	14
4.1.	INTERNAL CONNECTIONS	15
4.2.	COM LOOP	15
4.2.1.	EXAMPLE OF COM LOOP WIRING	16
4.3.	PROGRAMMABLE VOLTAGE OUTPUTS (S1)	17
4.4.	PROGRAMMABLE INPUTS (I1-I2)	17
4.4.1.	USED AS GENERAL INPUT	17
4.5.	RELAY OUTPUTS FOR ROUTING EQUIPMENT (TX)	18
4.5.1.	FIRE ALARM OUTPUT	18
4.5.2.	FAULT CONDITION OUTPUT	18
4.6.	BALANCED INTERFACE FOR ROUTING EQUIPMENT	19
4.6.1.	FIRE ALARM INTERFACE	19
4.6.2.	FAULT CONDITION INTERFACE	19
4.7.	POWER SUPPLY 24 V FOR GATEWAY	19
4.8.	POWER SUPPLY OUTPUT 1	19
4.9.	POWER SUPPLY OUTPUT 2	19
<b>5.</b>	<b>MOUNTING</b>	20
5.1.	WIRING	22
5.2.	COMMISSIONING	22
<b>6.</b>	<b>INSTALLATION AND WIRING</b>	24
6.1.	WIRING OUTSIDE THE BUILDING	25
<b>7.</b>	<b>MAINTENANCE</b>	26

7.1.	DE-ENERGIZATION THE CIE	26
7.2.	REMOVAL OF THE LCD MODULE	26
7.3.	REPLACEMENT OF THE MAIN BOARD	27
7.4.	REPLACEMENT OF BATTERIES	27
7.5.	REPLACEMENT OF THE LCD MODULE	28
7.6.	REPLACEMENT OF POWER SUPPLY	29
7.7.	START UP THE CIE	29
<b>8.</b>	<b>TROUBLESHOOTING</b>	<b>30</b>
8.1.	EARTH FAULT	30
<b>9.</b>	<b>TECHNICAL DATA 2000</b>	<b>31</b>
<b>10.</b>	<b>APPROVALS</b>	<b>32</b>

# 1. INTRODUCTION

This document describes the control and indicating equipment (CIE), type number 2000.

The document contains information about the product and instructions on how to mount and connect it.

<b>Article no</b>	<b>Product name</b>
2000	EBLOne
2000K	EBLOne with key

## 2. SAFETY INSTRUCTIONS

This chapter describes precautions that must be followed to reduce the likelihood of pain, injury and, in the case of fire, property damage.

### 2.1. PERSONS

#### 2.1.1. ORDINARY PERSON

An ordinary person – as not instructed or skilled – may have access to the location of this equipment and might also be expected to investigate and initially respond to a fire alarm or fault warning.

An ordinary person must not have access to operate the CIE.

This equipment is not suitable for use in locations where children are likely to be present.

#### 2.1.2. INSTRUCTED PERSON

An instructed person - a person who have been instructed and trained by a skilled person, or who are supervised by a skilled person.

An instructed person have access to the buttons on the touch screen and the menu system. The access is given by entering a password (six digits). For EBLOne with article no. 2000K, access to the buttons on the touch screen is also given with a fire brigade key.

An instructed person must not dismantle the cover of the CIE.

*National regulations must be followed.*

#### 2.1.3. SKILLED PERSON

A skilled person has the training and experience in the equipment technology, particularly in knowing the various energies and energy magnitudes in the equipment. Skilled persons are expected to use their training to take action for protection from injury from those energies.

Only a skilled person may have access to the CIE when the cover is dismantled.

Only a skilled person may connect and deploy the CIE.



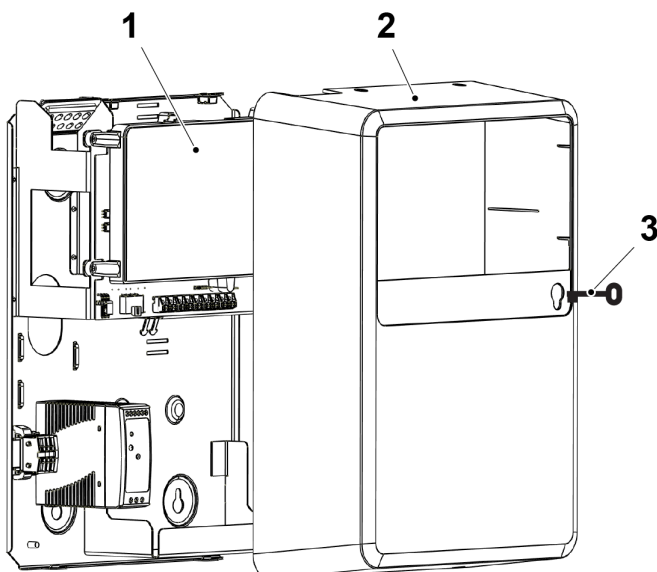



*National regulations must be followed.*

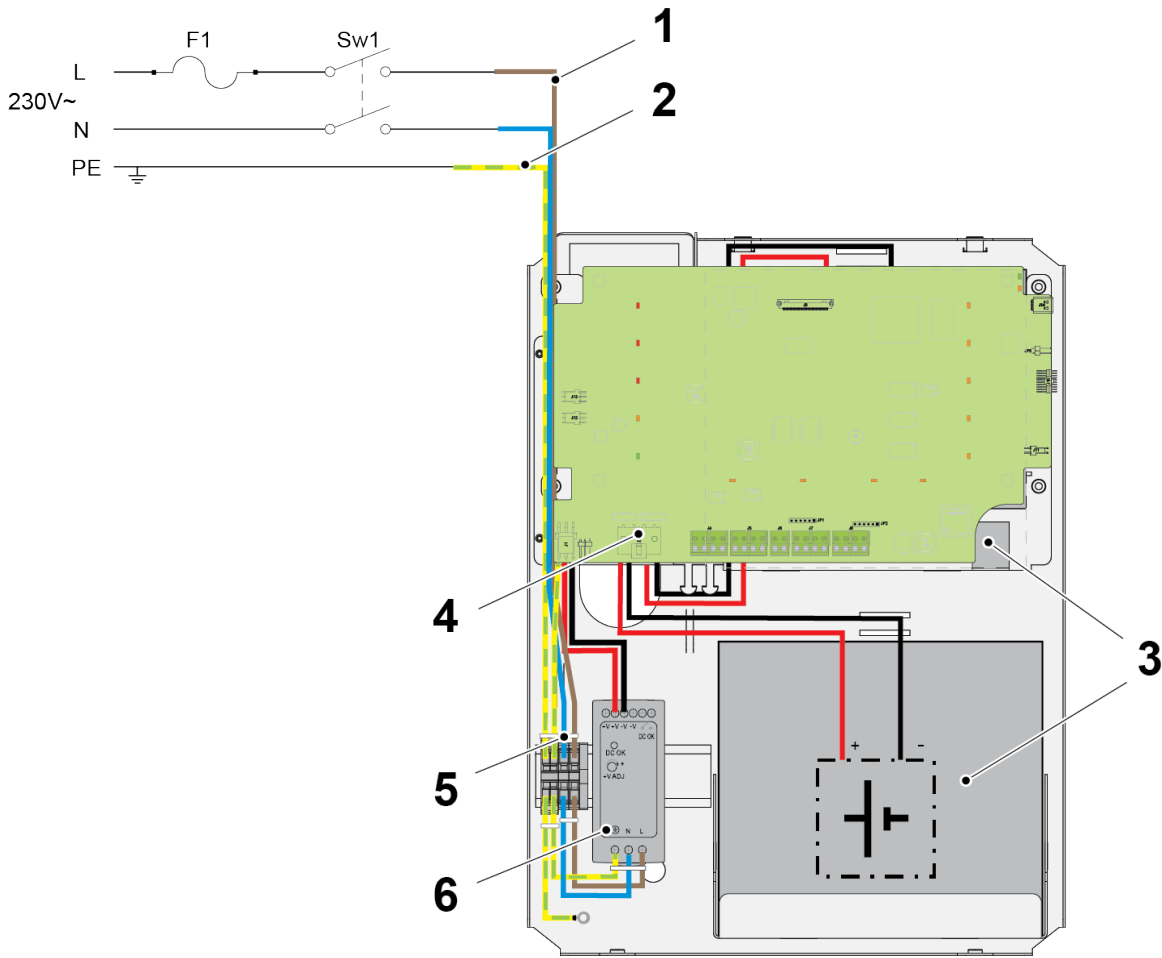

1. Touch screen
2. Cover
3. Key, only to article no. 2000K

## 2.2. WARNINGS



Element	Description	Markings / Instructions
1	Caution! Risk of electric shock. Dangerous voltage. Make sure to disconnect the equipment from the mains power supply before removing the cover of CIE.	
2	NOTE! Protective earth (ground). Make sure to connect the protective earth conductor when installing the CIE.	
3	Caution! Risk of explosion if batteries are replaced by incorrect type. See <a href="#">3.8. BATTERIES</a> on page 12.	
4	Caution! Risk of electric shock. Make sure to disconnect the terminal block J2 for the backup batteries before touching anything in the CIE.	 CAUTION!
5	Caution! Risk of electric shock. Long cable cores should be safely secured, not to touch high/low voltage parts if becoming loose from its terminal. For example; secure with a cable tie.	 CAUTION!
6	Caution! Hot parts! Risk of burned fingers when touching hot electrical components. Do not touch any electrical components when the unit is powered.	 CAUTION!

## 3. GENERAL DESCRIPTION

The control and indicating equipment is a unit, to which the alarm points are connected via the COM loop. It indicates fire alarm, fault condition, and so on. EBLOne can have up to 253 addresses, and up to 253 alarm points.

The unit is intended for indoor use and in dry premises.

EBLOne conforms to the European standard EN54, part 2 and 4.

### 3.1. OPTIONS

EN 54-2 options with requirements	Clause in EN 54-2:1997/A1:2006
Output to fire alarm devices	7.8
Output to fire alarm routing equipment	7.9.1
Delays to outputs	7.11.1 b) + c) + d) + e) + f)
Dependencies on more than one alarm signal (Type B)	7.12.2
Alarm counter	7.13
Fault signals from points	8.3
Output to fault warning routing equipment	8.9
Test condition	10
Standardized input/output interface	11

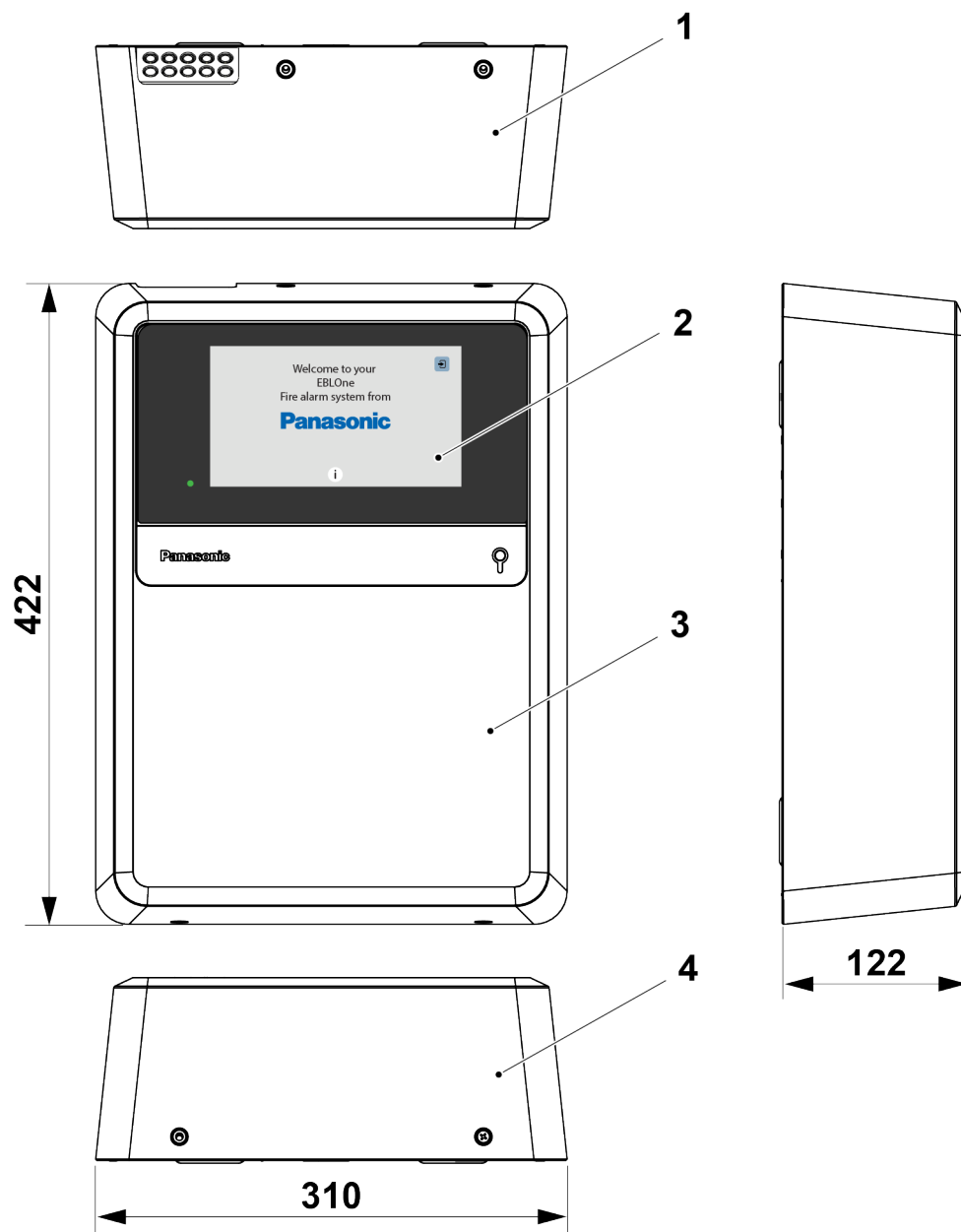

(Measures in mm)

- 1. CIE cover top
- 2. LCD
- 3. CIE front
- 4. CIE cover bottom

## 3.2. TOUCH SCREEN

The display is a colour touch screen.

Data:

- Display size: 7.0"
- TFT Screen LCD type
- Capacitive display
- Resolution: 1024 x 600 RGB

There are 12 status LEDs integrated in the display module:

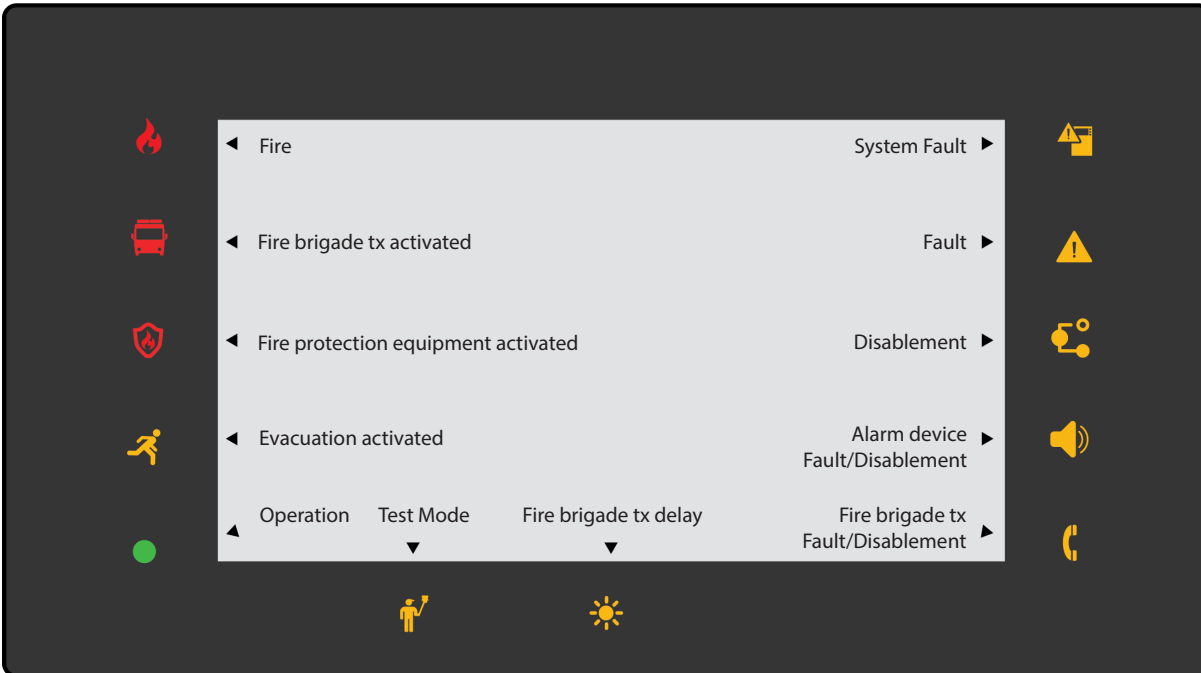

In case of no fire alarms, faults, disablements or test condition, the touch screen will go into sleep mode after 2 minutes.

## 3.3. ALARM PRESENTATION

In case of fire alarms the fire brigade personnel are able to see which alarm point/points having activated fire alarm and to take required operating control of the system.

The information displayed in the upper part is depending on how many alarm points having activated fire alarm. In the middle part will the fire alarms be shown, one alarm point together with an user definable alarm text (if programmed).

## 3.4. CONTROL PANEL

The touch screen is also used for CIE operations such as commissioning, monthly test and maintenance. To get access to operate the CIE, a user name and password is required. Up to ten user names can be used for three different user level types.

A password (six digits) for each user name is required.

See EBLOne Operating instructions for more information about status LEDs, alarm presentation and the control panel.

## 3.5. USB

The CIE is equipped with an USB interface (Type C), used for PC connection.

## 3.6. MAIN BOARD

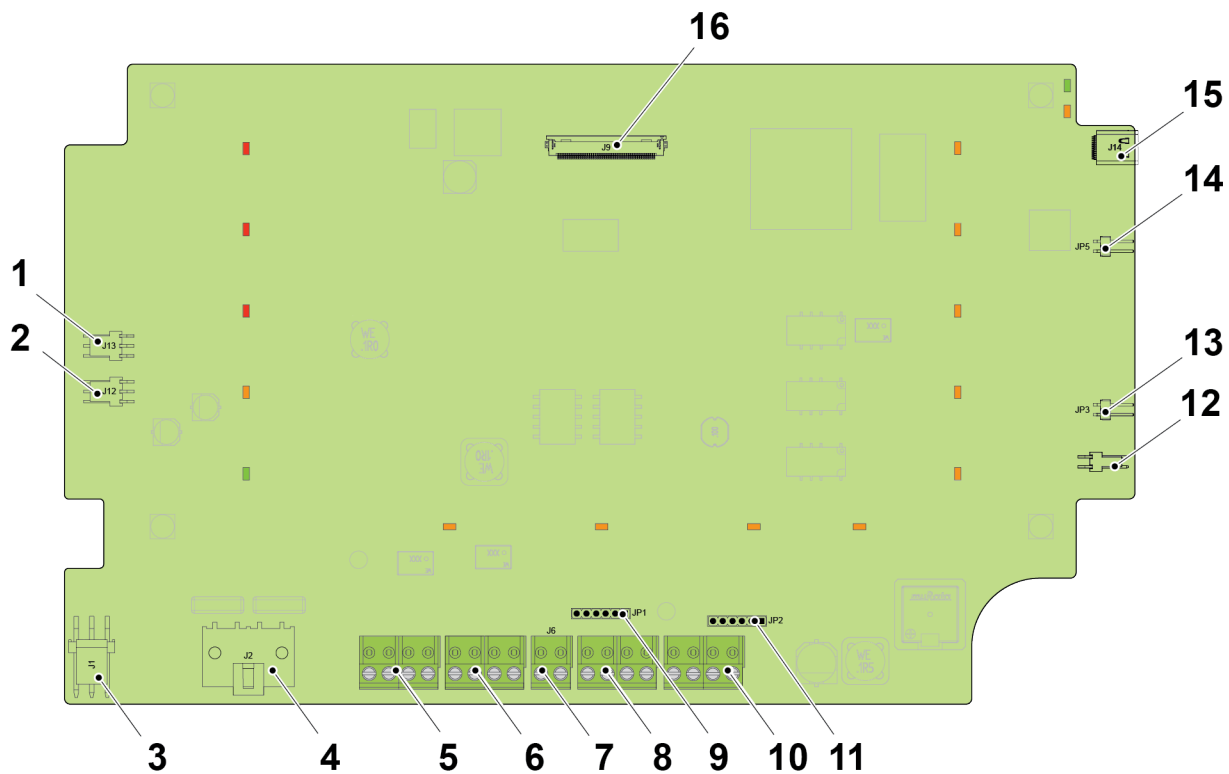

For more information on J1 – J8, see chapter 4. CONNECTIONS IN THE CIE on page 14.

1. J13, RS232 for Gateway
2. J12, 24V for Gateway
3. J1, 24V from power supply
4. J2, batteries
5. J4, COM Loop
6. J5, 24V for external units
7. J6, S1
8. J7, I1 and ATX
9. JP1
10. J8, I2 and FTX
11. JP2
12. J11, Optional Key
13. JP3, Buzzer enabled (must be jumpered)
14. JP5, Boot
15. J14, USB port (USB 3.1 type C)
16. J9, Connector for LCD

### 3.7. CIE CHASSIS

The chassis is to be mounted on the wall.

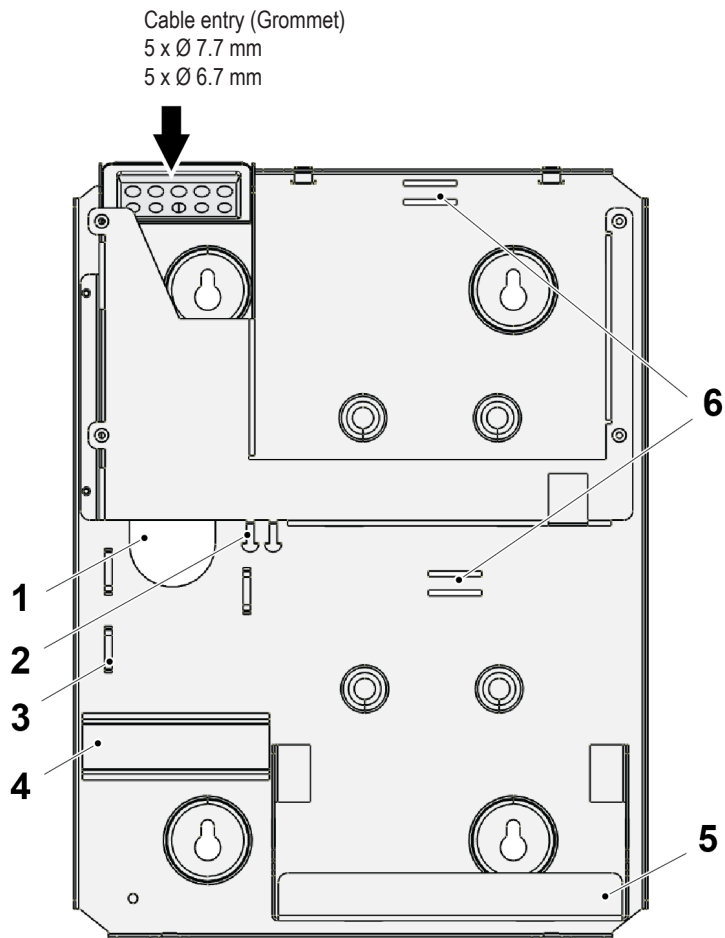

1. Cable entry opening 47 x 70 mm
2. Cable shield holder
3. 3 x cable holder
4. Symmetric 35 mm DIN rail for mains connection, power supply and Gateway (option)
5. 2 x battery shelf
6. 2 x hole for battery straps

## 3.8. BATTERIES



### **CAUTION!**

*Risk of explosion if battery is replaced by an incorrect type. Dispose used batteries according to instructions.*

*The batteries are not included in the CIE.*

*When only one battery is used, connect both battery cables from plug-in connector J2 to the battery.*

*Only insulated tools are to be used for battery installation / maintenance.*

By loss of 230V AC the control unit is powered by backup batteries, one or two sealed lead-acid batteries, VRLA cells, 12 V, 17 Ah.

- MAX physical size 168 x 182 x 78 mm (H x L x W) inside CIE.
- Batteries shall fulfil UL94 V-1 or better, including a relevant VRLA battery safety standard (IEC, EN, UL).
- Only batteries with a specified "Final voltage" of 10.5 V must be used.
- Max operating temperature during charging: 50°C
- The batteries shall be marked with their type designation and code or number identifying the production period.

Battery charging will be turned off during fire alarm condition.

See also EBLOne Planning instructions.

## 3.9. POWER SUPPLY

The main power source is a built-in switched mode power supply, 230V AC, 1.1 A / 24V DC, 1.7 A.

In quiescent condition  $\leq 300$  mA is available for connected equipment.

In fire alarm condition  $\leq 1.15$  A is available for connected equipment.

Internal wiring (in the CIE) must fulfill IEC 60332, 60695-11-21, or UL2556 (Flammability test).

External wiring (outside the CIE) must have a diameter  $> 0.4$  mm (AWG 26). Otherwise it must be secured with a fuse, max 1A.

National regulations must be followed.

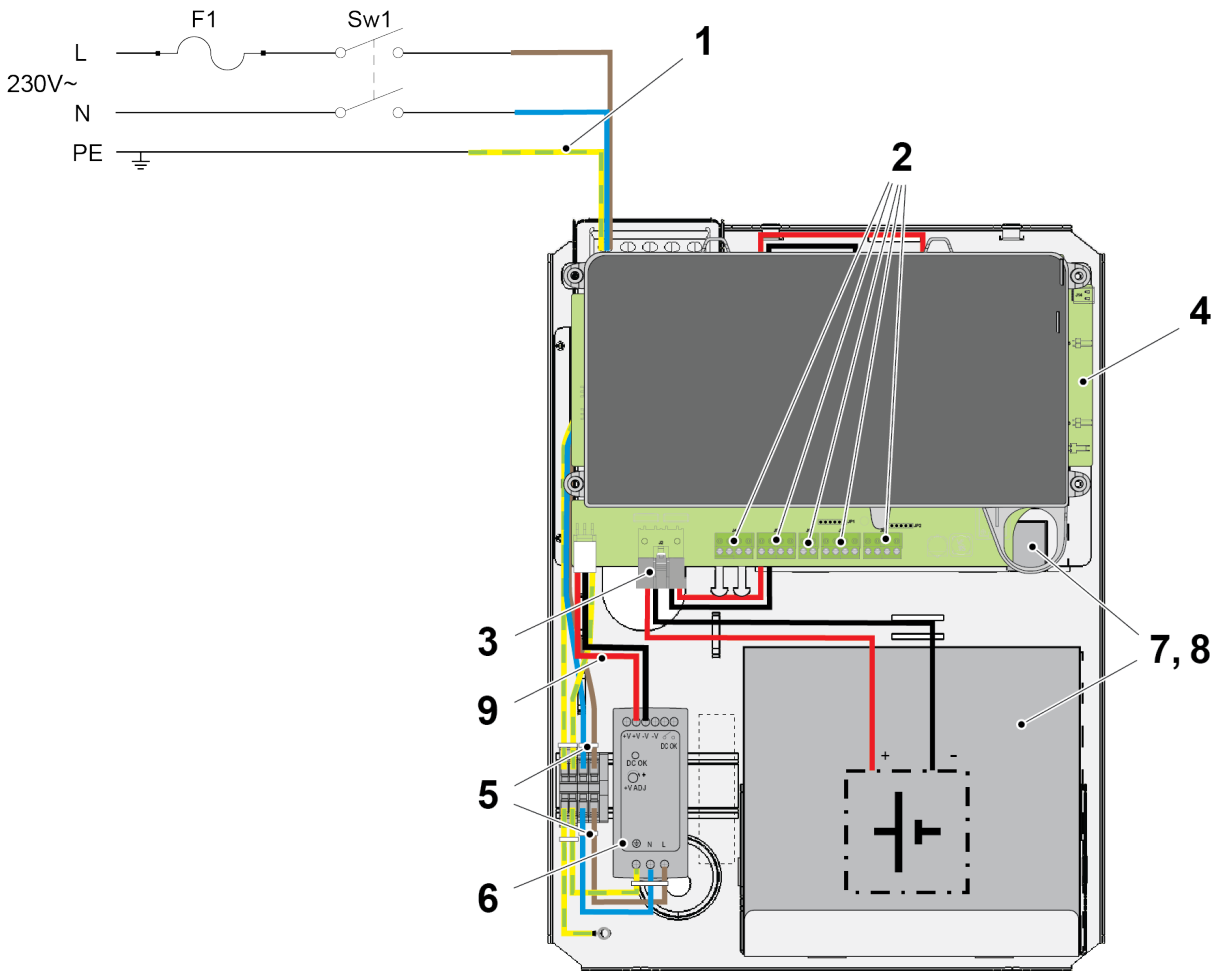

**CAUTION!**  
The control unit has two energy sources.

Power supply function in CIE	Min / max voltage	Min / max current
1 Mains, 230 V AC	195V / 253V AC	
2 Output current for continuous use. ( $I_{max}^a$ ) Output current for continuous use, no battery charging. ( $I_{max}^b$ ) Output voltage	22.0 / 25.0V DC	300 mA 1150 mA
3 Battery charging current from main board to the battery.	10.0 - 14.5V, Nom 13.65V	Max 1.3A
4 Main board	-	110 mA / 240 mA
5 Cable tie to keep the 24V DC conductors well separated from the mains conductors	-	-
6 Power supply, 230V AC, 1.1 A / 24V DC, 1.7A	-	-
7 Internal batteries 2 x 12V, 17 Ah or 1 x 12V, 17 Ah	-	-
8 Battery supply, by loss of 230V AC. R <sub>lmax</sub> : 0.5 Ω / battery	9.7 / 14.5V	-
9 Internal Power Supply Output	23.8 / 24.2V	Max 1.7A

### 3.9.1. DISCONNECT DEVICE

Appropriate disconnect device (all-pole mains switch) shall be provided as a part of the building installation, see SW1 in illustration above. The disconnect device shall have a contact separation of at least 3 mm.  
Mount a two-way circuit breaker, outside and close to the CIE. The circuit breaker is to be used by service / maintenance personnel.

## 4. CONNECTIONS IN THE CIE

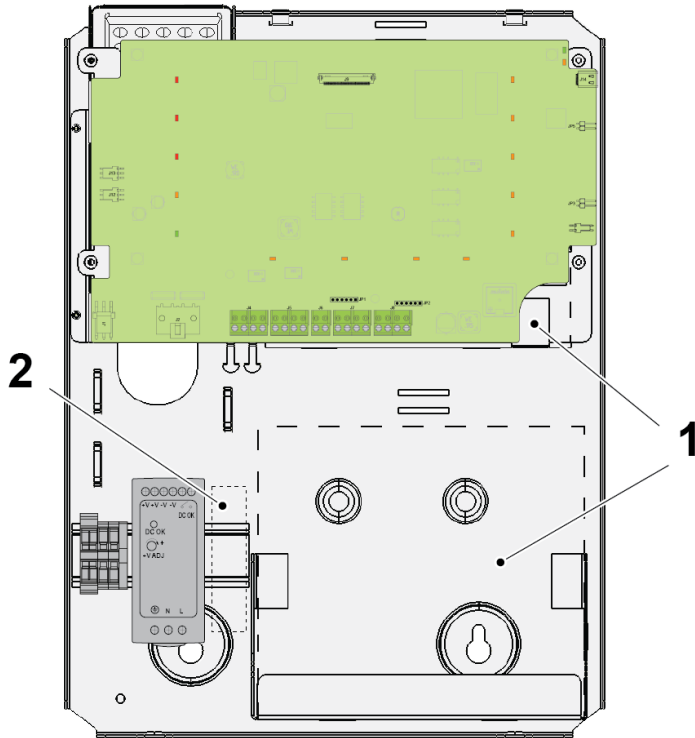

1. Position for backup batteries
2. Position for Gateway

### J4

- COM loop

### J5

- Power supply output 1
- Power supply output 2

### J6

- Supervised voltage output S1

### J7

- Input I1
- Fire brigade TX

### J8

- Input I2
- Faults TX

### J1

- Connection to rectifier

### J2

- Connection to batteries

### 2010

- Mainboard

### Power supply

- Power supply unit, rectifier

## 4.1. INTERNAL CONNECTIONS

The batteries and power supply are connected to the main board, which handles the charging of the batteries.

### Plug-in connector J1 Power supply

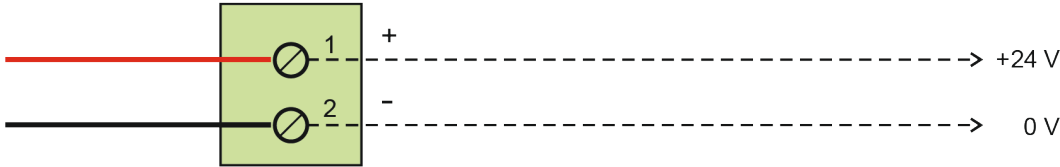

### Plug-in connector J2 Batteries

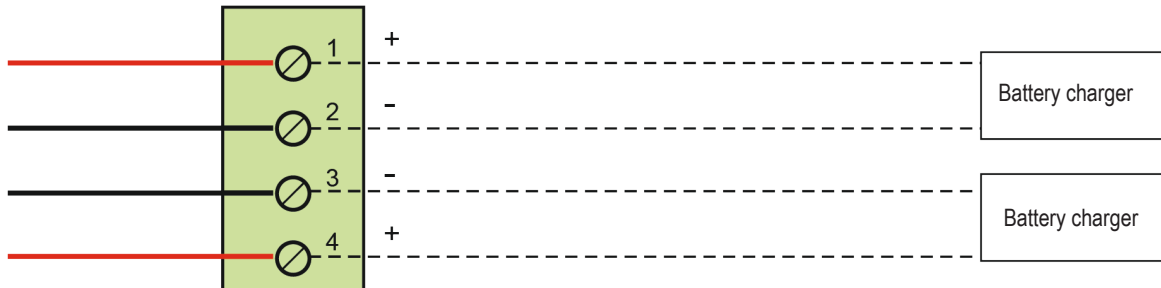

## 4.2. COM LOOP

EBLOne has one COM loop. On the COM loop, up to 253 addressable COM loop units can be connected (address 001-253). Regarding type and number of COM loop units in relation to the cable length / type, see chapter "COM loop cable length" and "Current consumption" in EBLOne Planning instructions.

Each COM loop unit has a COM loop address (for example 123) also designated Technical address.

Each alarm point and zone line input has a fire alarm presentation number (Zone-address), for example 001-01. See EBLOne Operating Instructions for more information.

The CIE sends data by changing the polarity on the loop.

Voltage on the loop terminals:  $24.0\text{ V} \pm 1.5\text{ V}$ .

The COM loop is LPS output (Limited Power Source). The COM loop outputs has maximum effect below 100W.

Maximum loop current: 350 mA.

COM loop is connected to terminal block J4: 1-4.

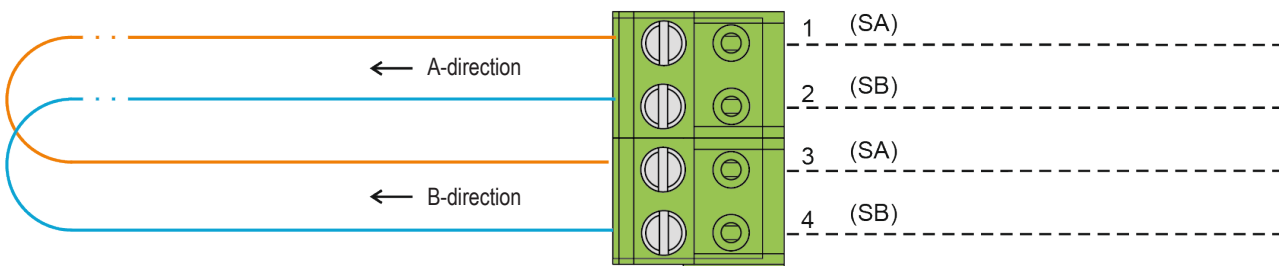

## 4.2.1. EXAMPLE OF COM LOOP WIRING

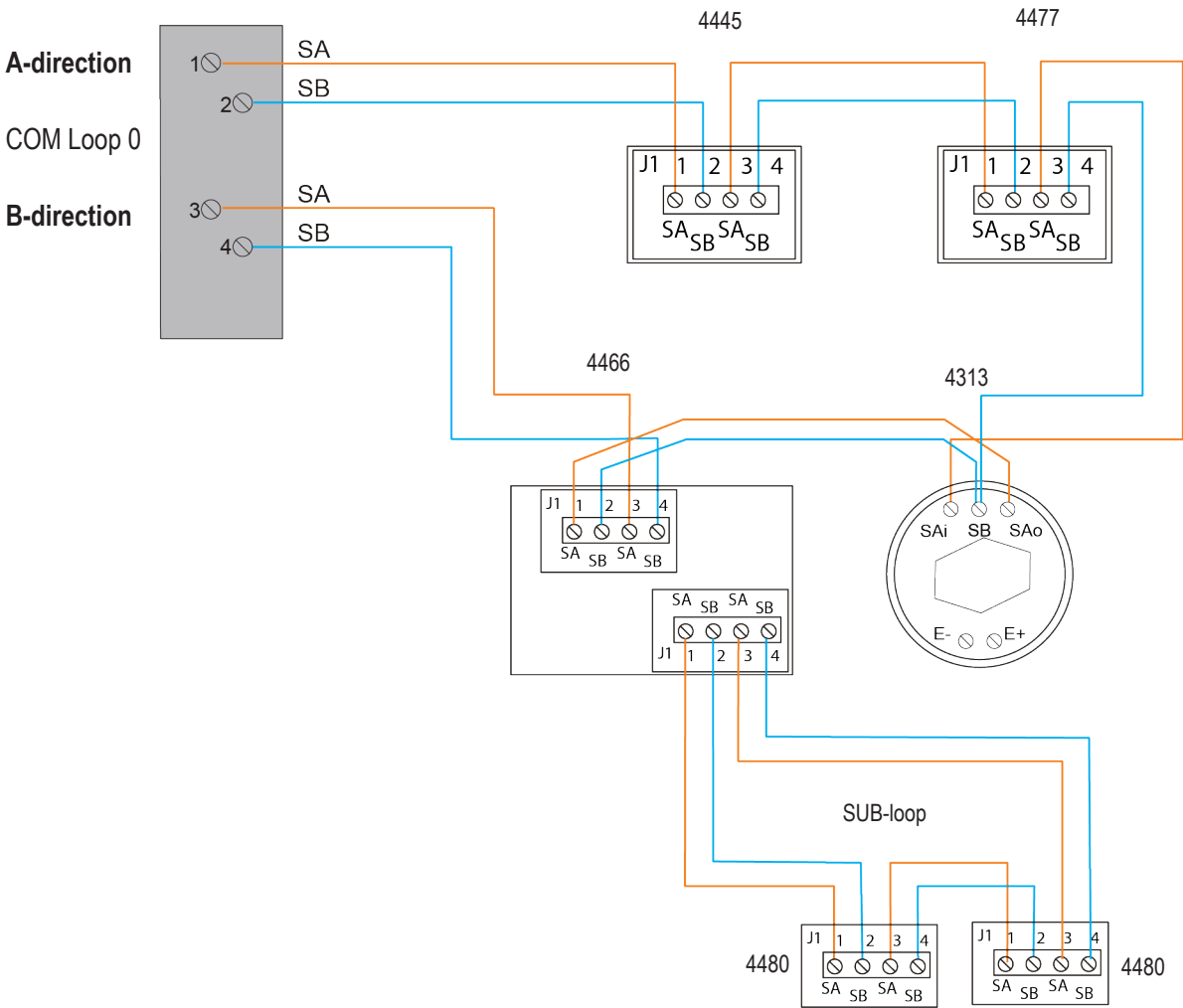

Wire size (Min)	Ø 0.6 mm (0.3 mm <sup>2</sup> )
Wire size (Max)	Ø 1.6 mm (2 mm <sup>2</sup> )

### 4.3. PROGRAMMABLE VOLTAGE OUTPUTS (S1)

The 24 V DC output S1 is normally supervised. The output is in EBLWin default set as supervised, but via EBLWin it is possible to set the output to be not supervised or supervised with EOL. LPS output.

<b>Voltage</b>	
Active:	22.0 – 25.0 V DC (nom. 23.5 V DC)
Supervised:	~ - 5 V DC
<b>Current</b>	
Active:	≤ 250mA
Supervised:	~ - 1 mA
<b>Line resistance RL:</b>	≤ 32 Ohm depending on current outtake and allowed voltage of the connected device.

Outputs S1 is protected by a resettable PTC Fuse.

S1 is connected to terminal block J6: 1-2.

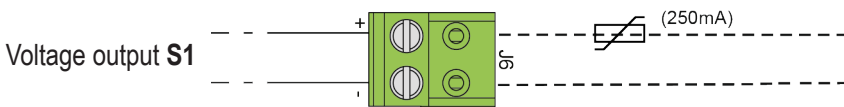

See also chapter Programmable outputs in EBLOne Planning instructions.

**For EN54-13 compliance, End-of-line device type 4472 shall be mounted after the last unit on the line.**

### 4.4. PROGRAMMABLE INPUTS (I1-I2)

In the CIE are two programmable inputs (I1-I2) available. Each input can either be used as a general input or as interface to an alarm transmission or fault warning routing equipment.

JP1*		JP2*	
Open	Shunted	Open	Shunted
I1 used as a general input.	I1 used as interface to an alarm transmission routing equipment (ATX).	I2 used as a general input	I2 used as interface to a fault warning routing equipment (FTX).

\* Note, JP1 and JP2 consist of three jumpers each, all three jumpers shall be either open or shunted. JP1 and JP2 are default set to open.

#### 4.4.1. USED AS GENERAL INPUT

Input used as general input. All three jumpers on JP1 and JP2 shall be open.

##### NOT SUPERVISED

Normally open (R > 100k Ohm)

Normally closed (R < 10k Ohm)

Activation time: > 1 sec.

I1-I2 are connected to terminal block J7: 1-2 and terminal block J8:1-2.

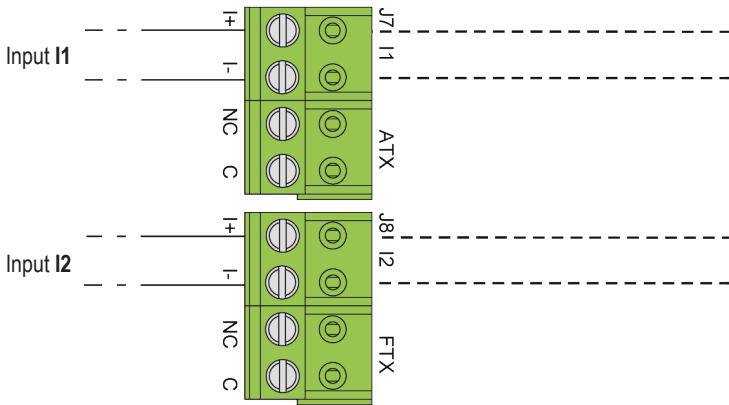

See also chapter Programmable inputs in EBLOne Planning instructions.

## 4.5. RELAY OUTPUTS FOR ROUTING EQUIPMENT (TX)

Not programmable outputs.

R1-R2 are connected to terminal block J7: 3-4 and terminal block J8:3-4.

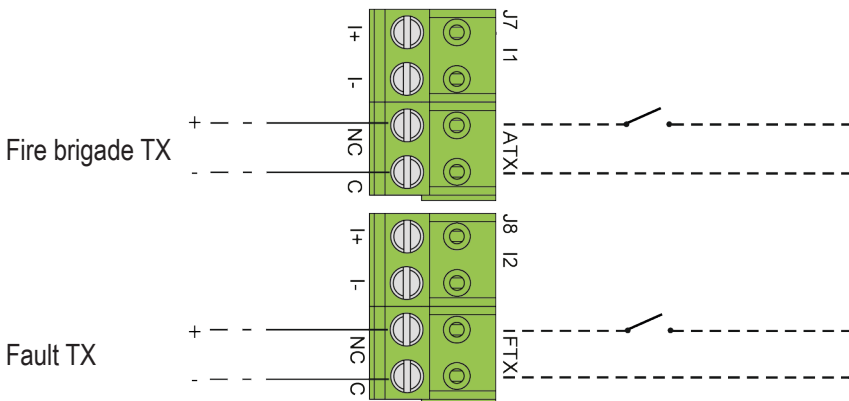

### 4.5.1. FIRE ALARM OUTPUT

This output is normally used for fire brigade tx. All three jumpers on JP1 shall be open.

It is a change-over relay contact that will be activated when a fire alarm is generated in the system. The relay output is normally closed. The output will be open during fire alarm.

### 4.5.2. FAULT CONDITION OUTPUT

This output is normally used for fault warning routing equipment (fault tx). All three jumpers on JP2 shall be open.

It is a changeover relay contact that is normally activated and will be de-activated in case of a fault in the CIE. Also when the CIE is out of power or watch-dog fault. The relay output is normally closed. The output will be open during fault condition.

## 4.6. BALANCED INTERFACE FOR ROUTING EQUIPMENT

Input used in combination with corresponding output to create a balanced line to routing equipment.  
The function is tested with routing equipment type Cat12CE and IRIS-4.

I1 must be programmed as 'Alarm routing equipment fault' (normally closed)

I2 must be programmed as 'Fault warning routing equipment fault' (normally closed)

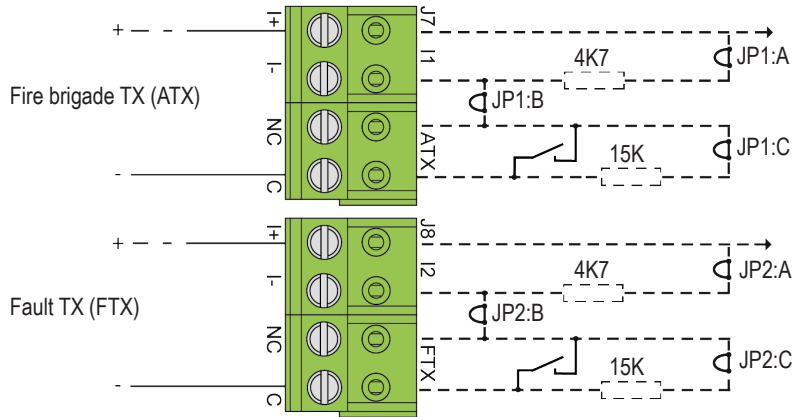

*The routing equipment must be power supplied via control unit.*

*The routing equipment must be placed outside the control unit, with maximum 3 meters of cable in between.*

### 4.6.1. FIRE ALARM INTERFACE

Input used as interface to an alarm transmission routing equipment (ATX). All three jumpers on JP1 shall be shunted.

### 4.6.2. FAULT CONDITION INTERFACE

Input used as interface to an fault warning routing equipment (FTX). All three jumpers on JP2 shall be shunted.

## 4.7. POWER SUPPLY 24 V FOR GATEWAY

Voltage: 22.0 – 25.0 V DC (nom. 24.0 V DC), Max. 150mA (Resettable fuse). LPS output.

## 4.8. POWER SUPPLY OUTPUT 1

Voltage: 22.0 – 25.0 V DC (nom. 24.0 V DC), Max. 250mA (Resettable fuse). LPS output.

## 4.9. POWER SUPPLY OUTPUT 2

Voltage: 22.0 – 25.0 V DC (nom. 24.0 V DC), Max. 150mA (Resettable fuse). LPS output.

## 5. MOUNTING

The CIE must be mounted on the wall. Screws are not supplied. EBLOne is approved for mounting on an incombustible wall, for example concrete.

- a) Mount the CIE chassis on the wall. Remove the power supply temporarily to reach the screw.

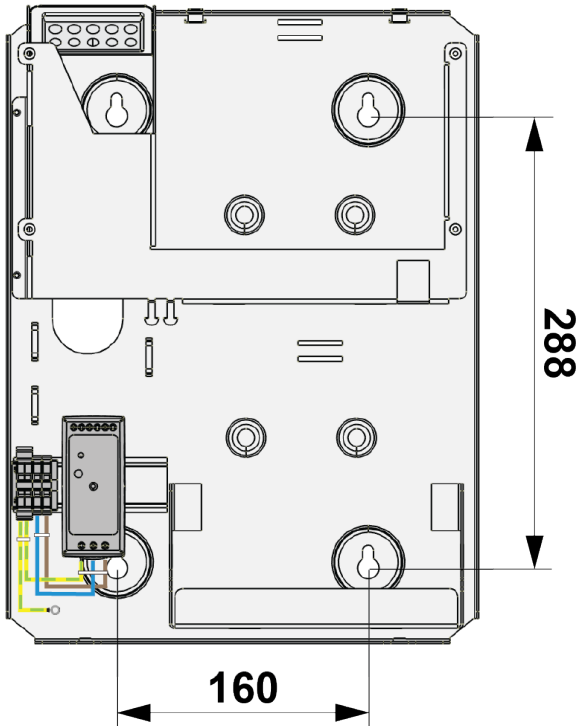

(Measures in mm)

- b) Mount the battery / batteries and fasten with the battery straps.

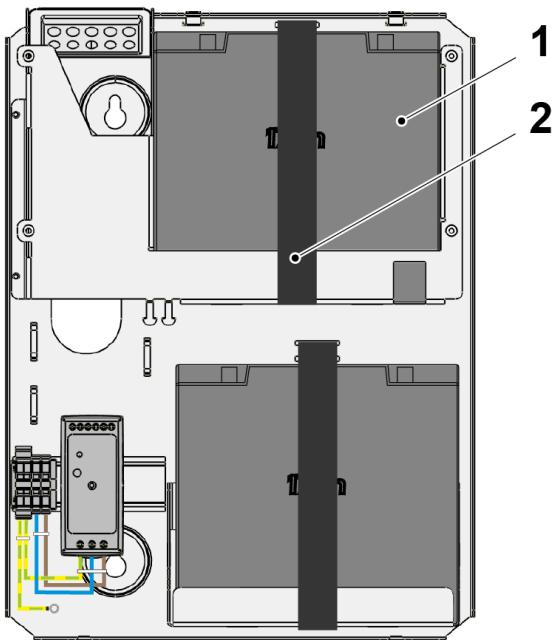

1. Battery
2. Battery strap

*It is recommended to connect the battery cables before mounting the LCD module.*

c) Mount the LCD module on the chassis with the four screws.

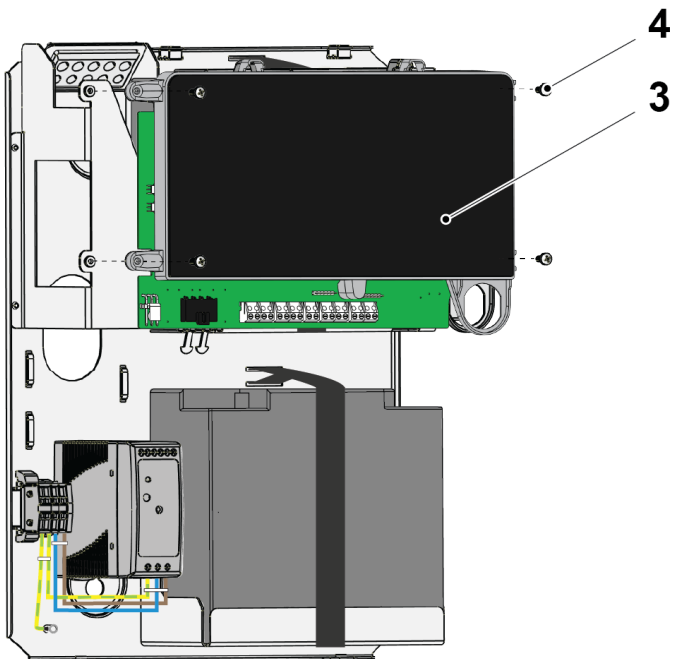

- 3. LCD module
- 4. Screw

## 5.1. WIRING

- a) Connect the battery cables to the battery / batteries.

*When only one battery is used, connect both battery cables from plug-in connector J2 to the battery.*

- b) Make the cable connections. Pull the cables through the cable gland on top of the chassis or through the hole in the back of the chassis.
- c) Use cable ties to fasten the 230 VAC cables to the two cable holders in the chassis, see arrows.

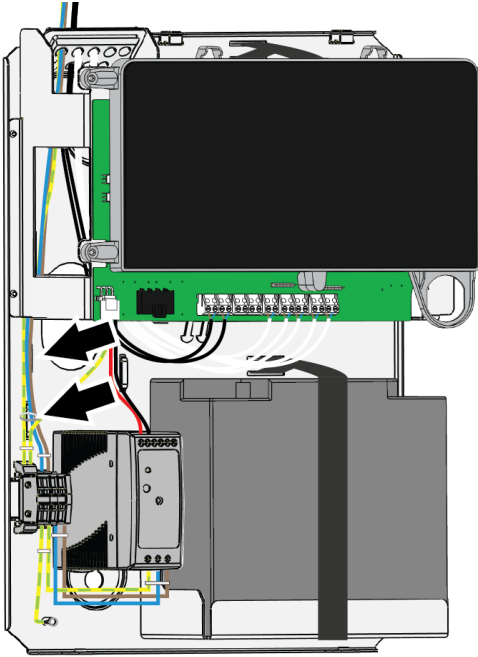

## 5.2. COMMISSIONING

Before you connect the power supply to the control unit, all other cable connections shall be made. Check once more that they are correct.

A tip! Measure the resistance of each loop wire (SA & SB respectively) before turning on the power. Check that the SA-wire that goes out on terminal J4:1 comes back at terminal J4:3 and so on. If the loop has short circuit isolators, only the SB-wire can be measured.

Also measure the resistance between the loop wires and 24V, 0V and Earth (J1:3,2,1). The resistance should be very high (mega ohm).

- a) Connect the rectifier to the mains (230V AC). A cable tie shall be mounted to keep the mains wires well separated from the 24V DC wires.

*It shall be connected to a household removable fuse for the fire alarm CIE only, via a two-way circuit breaker. National regulations must always be followed. The mains cable shall be securely clamped and the wires shall be as short as possible. The mains safety earth (ground) shall, however, be longer than the other wires, to ensure that it is the last to be disconnected if the mains cable clamp should fail.*

- b) Connect the 24V supply cable to connector J1.
- c) Connect the batteries (using the enclosed battery cables) to the main board, terminal block "J2".

*When only one battery is used, connect both battery cables from plug-in connector J2 to the battery.*

***RISK OF EXPLOSION IF BATTERY IS REPLACED BY INCORRECT TYPE. DISPOSE USED BATTERIES ACCORDING TO THE INSTRUCTIONS.***

- d) The CIE will do a restart, see chapter RESTART in Operating instructions.
- e) If it is the very first startup, select your language to be used in the control unit.  
If British language is selected, a pop-window will ask if you wish to change convention. British convention is selected by default.

*If the information button ⓘ is pressed before any language is selected, the service menu will be opened, mainly intended for Production to test LEDs.  
After 15 seconds of inactivity the screen will return to the Choose language page.*

- f) Put on the CIE cover on the chassis and fix with the four screws.

*The screws for the top and the bottom have different length.*

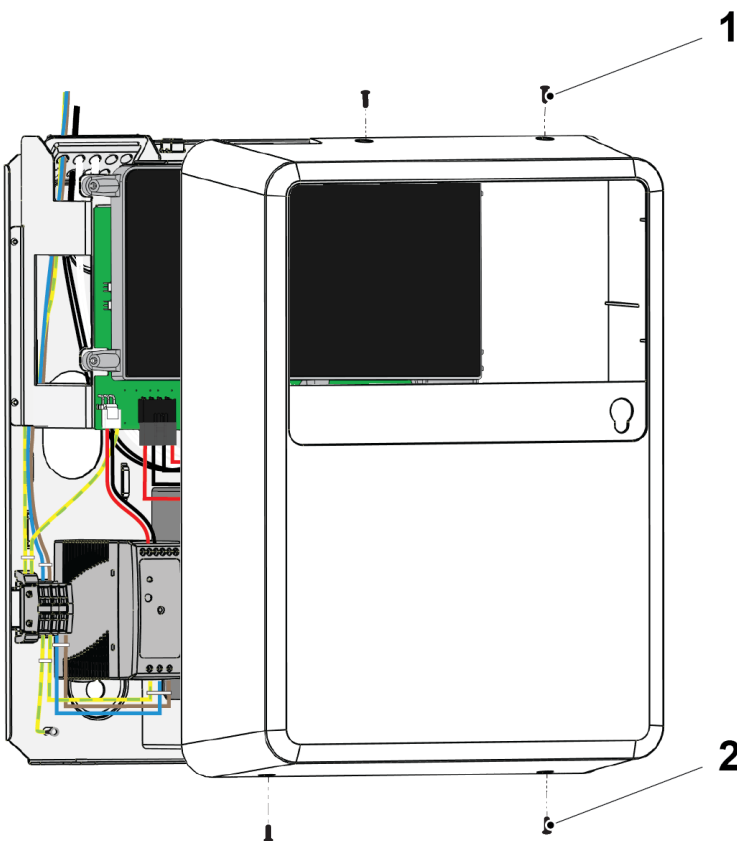

- 1. Screw (M4 x 16 mm)
- 2. Screw (M4 x 12 mm)

- g) You are now ready to configure the system. There is a wizard that will guide through the configuration, see Operating instructions. If configuration is not needed, SSD can be created and downloaded with EBLWin.

## 6. INSTALLATION AND WIRING



**CAUTION! Risk of electric shock!**

The control unit has two energy sources. Make sure to disconnect the equipment from the mains power supply before dismantling the cover from the CIE. Also make sure to disconnect the plug-in connector J2 for the backup batteries, before touching anything in the CIE.

The conductors shall be as short as possible. The mains protective earthing conductor shall be longer than the other conductors to ensure that it is the last to be disconnected if the mains cable clamp should fail.

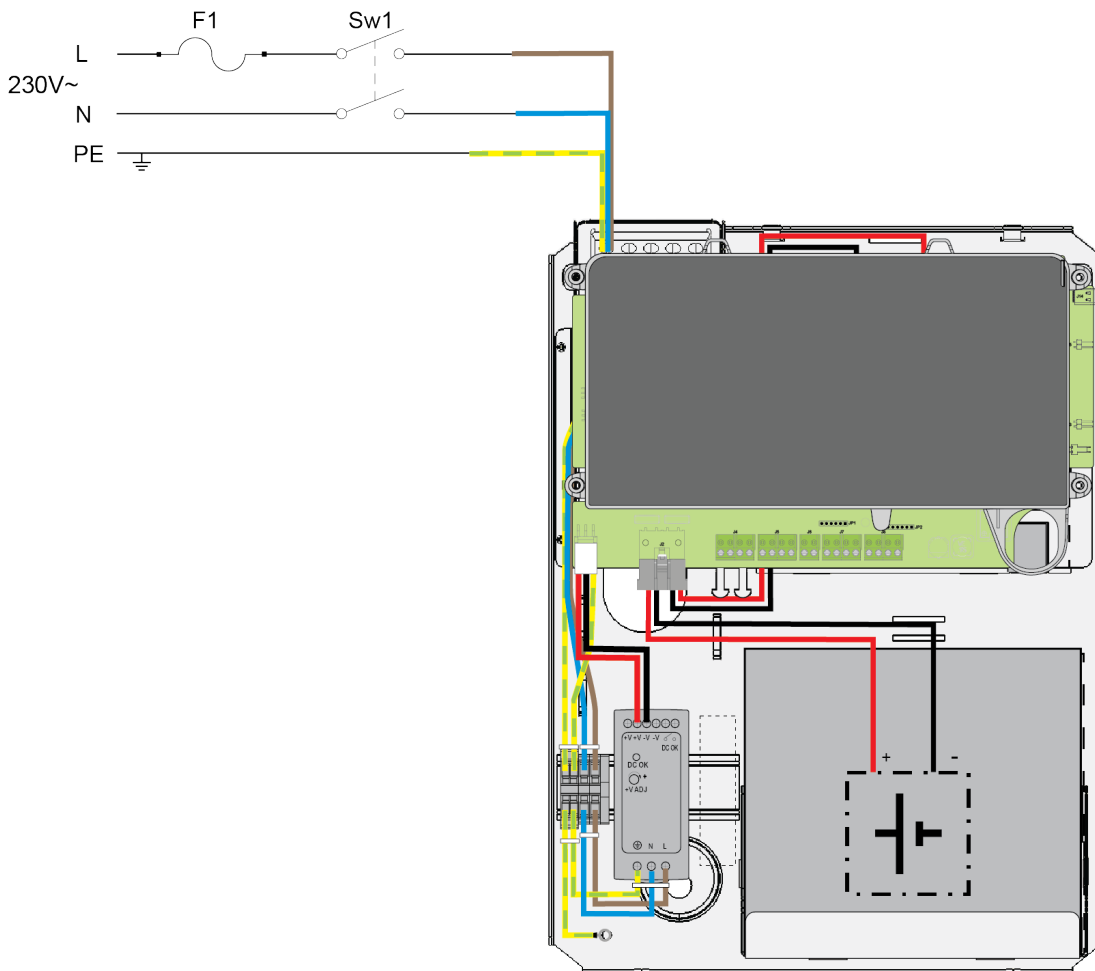

Mains is connected to a disconnect device, max 10 A, intended for the fire alarm CIE only, and marked according to national regulations and codes of practice. Use cable ties to keep mains and 24V DC wiring well separated.

EBLOne is intended for permanent installation, according to national regulations.

## 6.1. WIRING OUTSIDE THE BUILDING

If cabling should be drawn out of the building, it must be protected with a transient filter. Two filters are required for each cable type. One for each building.

Following type of transient filters can be used. They are adapted for grounded DIN rail.

Transient filters	
24V DC	EDL1V - 24 or ED20 - 24V DC
COM Loop, 1A	EDL1V - 24 or EDL2V - 24

## 7. MAINTENANCE

*Always carry out maintenance on the control unit in a de-energized state.*

### 7.1. DE-ENERGIZATION THE CIE

Before any maintenance, de-energize the control unit.

- a) Remove J2 to disconnect the batteries.
- b) Switch off the disconnect device.
- c) Remove J1 to disconnect the power supply.

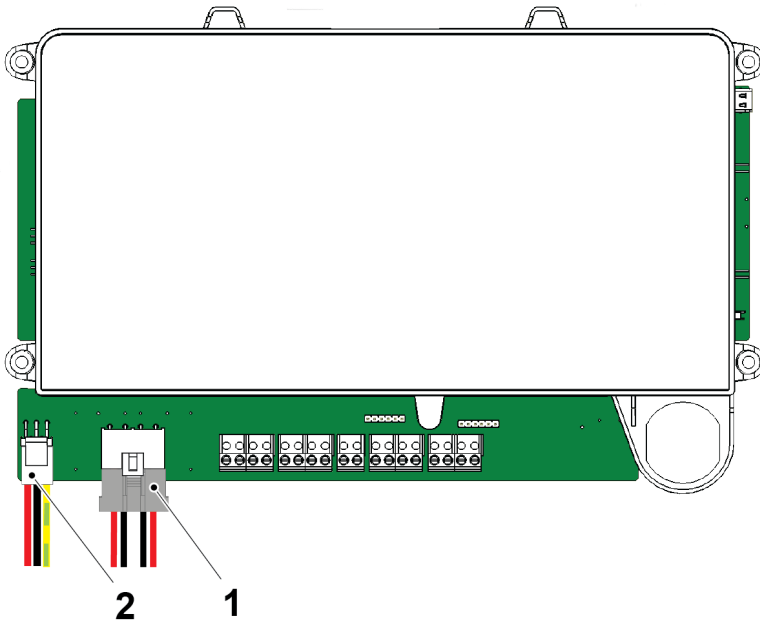

1. J2
2. J1

### 7.2. REMOVAL OF THE LCD MODULE

- a) De-energize the control unit, see 7.1. DE-ENERGIZATION THE CIE on page 26.
- b) Disconnect all the cables connected to the main board, see arrows.

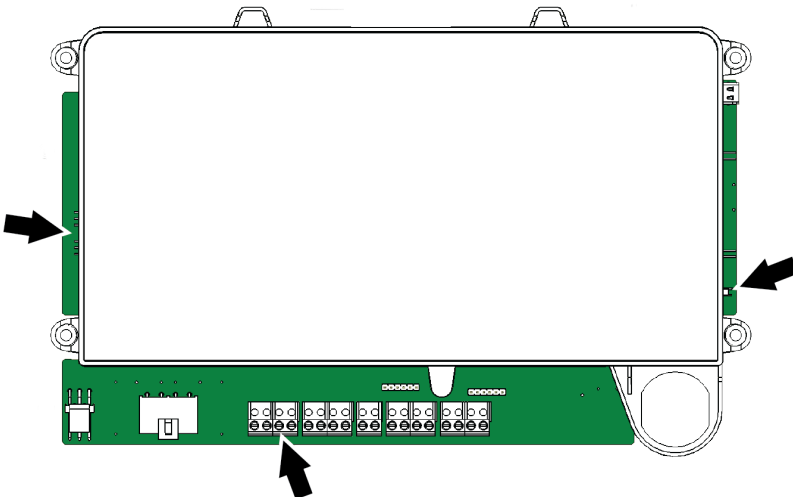

- c) Remove the four screws that hold the LCD module in place.

## 7.3. REPLACEMENT OF THE MAIN BOARD

- a) Remove the LCD module and place it on a clean surface, see [7.2. REMOVAL OF THE LCD MODULE](#) on page 26.
- b) Remove the six screws and the PCB.

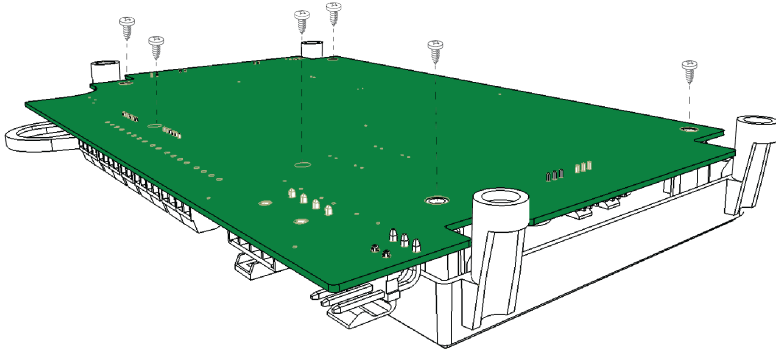

- c) Open the two pins and disconnect the LCD cable.

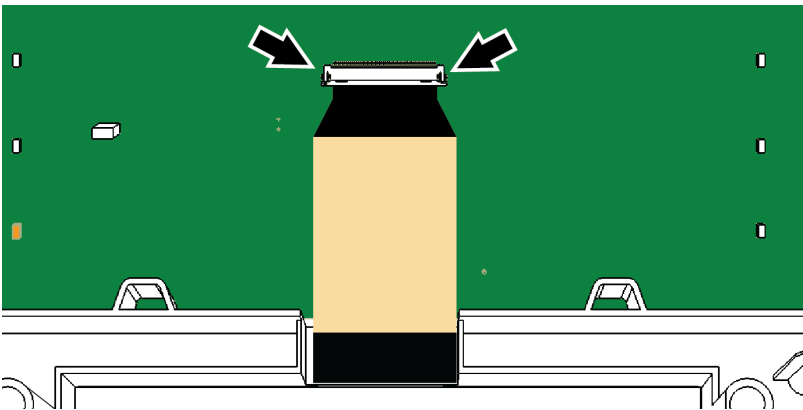

- d) Replace the main board.
- e) Re-assemble all parts in the opposite way
- f) Start up the CIE, [7.7. START UP THE CIE](#) on page 29.

*When connecting the LCD cable make sure that the cable slides in properly before closing the two pins.*

## 7.4. REPLACEMENT OF BATTERIES

- a) If two batteries are used, remove the LCD module and place it on a clean surface, see [7.2. REMOVAL OF THE LCD MODULE](#) on page 26.
- b) Loosen the battery straps holding the batteries.
- c) Disconnect the battery cables from the batteries.
- d) Replace the batteries.
- e) Connect the battery cables to the new batteries.

*When only one battery is used, connect both battery cables from plug-in connector J2 to the battery.*

- f) Fasten the battery straps.
- g) If removed, re-place the LCD module.
- h) Start up the CIE, [7.7. START UP THE CIE](#) on page 29.

## 7.5. REPLACEMENT OF THE LCD MODULE

- a) Remove the LCD module and place it on a clean surface, see [7.2. REMOVAL OF THE LCD MODULE](#) on page 26.
- b) Remove the six screws and the PCB.

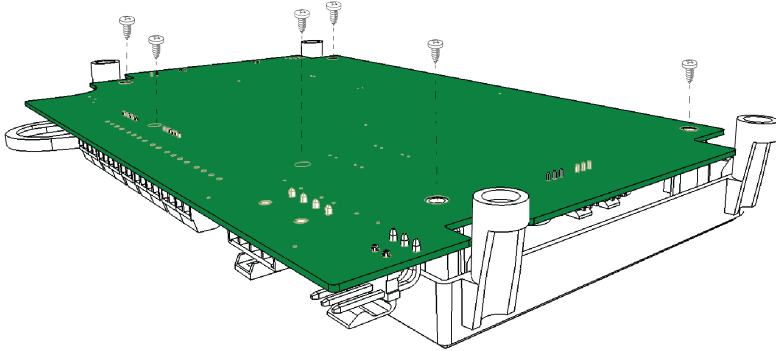

- c) Open the two pins and disconnect the LCD cable from J9.

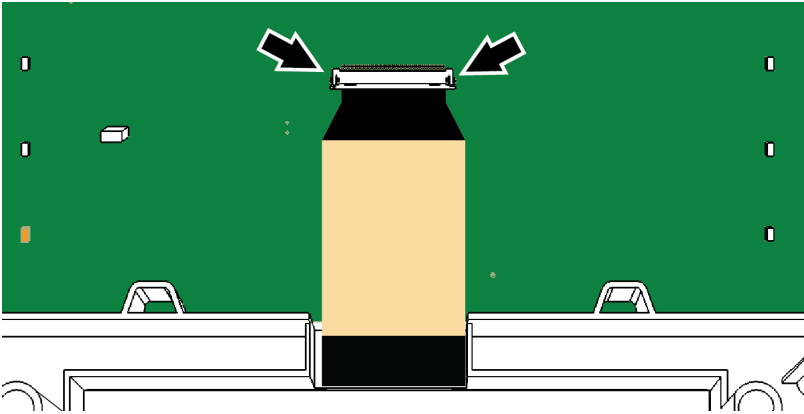

- d) Replace the LCD module.
- e) re-assemble all parts in the opposite way
- f) Start up the CIE, [7.7. START UP THE CIE](#) on page 29.

## 7.6. REPLACEMENT OF POWER SUPPLY

- a) De-energize the control unit, see [7.1. DE-ENERGIZATION THE CIE](#) on page 26.
- b) Disconnect the cables to the terminal block.
- c) Replace the power supply.
- d) Connect the black 24V DC cable to one of the terminals, marked -V.
- e) Connect the red 24V DC cable to one of the terminals, marked +V.
- f) Connect the brown 230V AC cable to terminal marked L.
- g) Connect the blue 230V AC cable to terminal marked N.
- h) Connect the yellow/green 230V AC cable to the terminal with the earth symbol.
- i) Start up the CIE, [7.7. START UP THE CIE](#) on page 29.

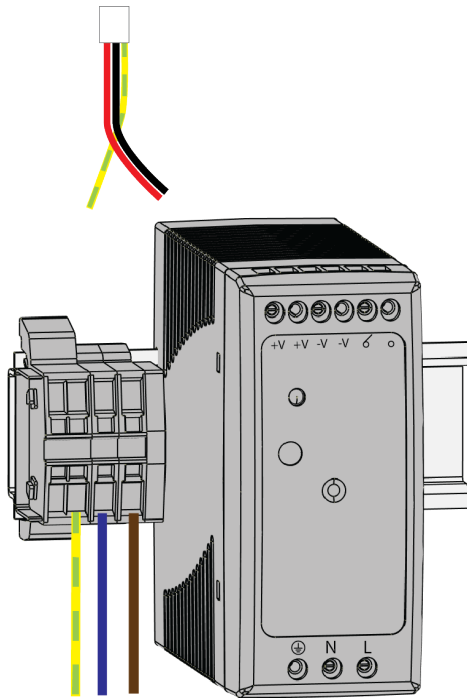

## 7.7. START UP THE CIE

- a) Reconnect the power supply cable to J1.
- b) Switch on the disconnect device.
- c) Reconnect the battery cables to J2.

### If main board has been changed:

- d) Download firmware.
- e) Download SSD.
- f) Perform calibration of outputs.
- g) Perform a safe shut down and restart the control unit.

## 8. TROUBLESHOOTING

### 8.1. EARTH FAULT

The earth voltage can be measured in two ways; either between earth and the rectifier or between earth and the batteries. If mains is connected the measurement should be done against the rectifier otherwise it should be done against the batteries.

The following tables show the nominal earth voltage:

Nominal earth voltage		
0V-to-Earth	+12.9V DC	(Control unit powered by mains)
B- -to-Earth	+14.2V DC	(Control unit powered by batteries)

The AC voltage is dependent on the rectifier. Best way is to turn off mains and let the control unit run on batteries. Then the AC voltage should be less than 0.5V.

## 9. TECHNICAL DATA 2000

*All current consumptions are valid by nominal voltage and by 25 °C.*

Voltage: Primary System	230V AC (195 - 253) 1.1 A, 50 Hz 24V DC
Rated output voltage	22.0 – 25.0V (Max ripple 300 mVp-p)
Current: Quiescent / Active	Max 1500 mA Depending on connected external equipment.
Number of addresses	Maximum 253
Number of alarm points	Maximum 253
Short circuit isolator	Yes, for one loop
Internal battery	Not included
Material	PBS / ABS
Ambient temperature: Operating Storage	-5 to +40 °C (indoor use only) -30 to +60 °C
Ambient humidity	Maximum 95 % RH (Non condensing)
Altitude	< 2000 m above sea level
Ingress protection rating	IP30
Acceptable pollution degree	Degree 1 and 2: None or dry, non-conductive pollution
Size: H x W x D	422 x 310 x 122 mm
Weight:	4 kg (no internal batteries)
Colour	RAL 9003

## 10. APPROVALS

Applicable directive/ Approval	Applicable standards	Notified body
CPR	EN54-2 EN54-4	RISE No. 0402-CPRC500347 No. 0402-CPRC500348
EMC	EN 55032 Class B (Emission) EN 50130-4 (Immunity)	RISE
LVD	EN IEC 62368-1	Intertek
RoHS	EN IEC 63000:2018	Self declaration



---

DOCUMENT NAME: TECHNICAL DESCRIPTION 2000  
DOCUMENT NUMBER: MEW02820 EN  
DATE OF ISSUE: 2022-10-07  
REV: 3  
DATE OF REVISION: 2024-09-20

**Panasonic Fire & Security Europe AB**

Jungmansgatan 12  
SE-211 11 Malmö  
SE  
Tel: +46 (0)40 697 70 00