



2840-2843

INTRINSICALLY SAFE ANALOG PHOTO- ELECTRIC SMOKE DETECTOR

Fire alarm solutions
technical description

Table of Contents

1.	INTRODUCTION	3
2.	ABBREVIATIONS	4
3.	GENERAL DESCRIPTION	5
3.1.	IS ANALOG PHOTOELECTRIC SMOKE DETECTOR 2840	5
3.1.1.	DETECTOR	5
3.1.2.	LED	5
3.2.	IS ANALOG HEAT DETECTOR 2841	6
3.2.1.	DETECTOR	6
3.2.2.	LED	6
3.3.	IS SAFE BARRIER UNIT	7
3.3.1.	POWER SUPPLY	7
3.3.2.	WATERPROOF BOX	7
3.4.	IS BACK-BOX	8
3.5.	RATING LABEL	8
3.6.	COMMUNICATION	8
4.	SET THE COM LOOP ADDRESS 2840 AND 2841	9
5.	SET THE MODE	9
5.1.	COMPATIBILITY TABLE 2840	9
5.2.	COMPATIBILITY TABLE 2841	9
5.3.	ALGORITHMS FOR 2840	10
5.4.	ALGORITHMS FOR 2841	10
6.	MOUNTING	11
6.1.	IS ANALOG PHOTOELECTRIC SMOKE DETECTOR 2840	11
6.2.	IS ANALOG HEAT DETECTOR 2841	11
6.3.	IS BARRIER UNIT 2842	12
6.4.	IS BACK-BOX 2843	13
7.	INSTALLATION AND WIRING	14
7.1.	CABLE GLAND	15
8.	TEST MODE	16
8.1.	TEST SMOKE DETECTOR (2840):	16
8.2.	TEST HEAT DETECTOR (2841):	16
9.	TECHNICAL DATA 2840	17
10.	TECHNICAL DATA 2841	18
11.	TECHNICAL DATA 2842	19
12.	APPROVALS	20

1. INTRODUCTION

This document describes the Intrinsically Safe units for Hazardous (Ex) areas, type number 2840-2843. The document contains information about the product and instructions on how to mount and connect it

2. ABBREVIATIONS

CIE	Control and indicating equipment	= control unit
LED	Light Emitting Diode	
IS	Intrinsically Safe	

3. GENERAL DESCRIPTION

In Hazardous (Ex) areas, Intrinsically Safe (IS) and approved products are required. The IS alarm points are connected to an interface outside the Ex area.

3.1. IS ANALOG PHOTOELECTRIC SMOKE DETECTOR 2840

The intrinsically safe analog photoelectric is used inside hazardous (Ex) areas. The detector is connected to the IS barrier unit 2842 via the IS COM line.

The detector can be mounted with or without the water-proof IS back-box 2843. The IP rating will be different depending on if the IP back-box 2843 is used or not.

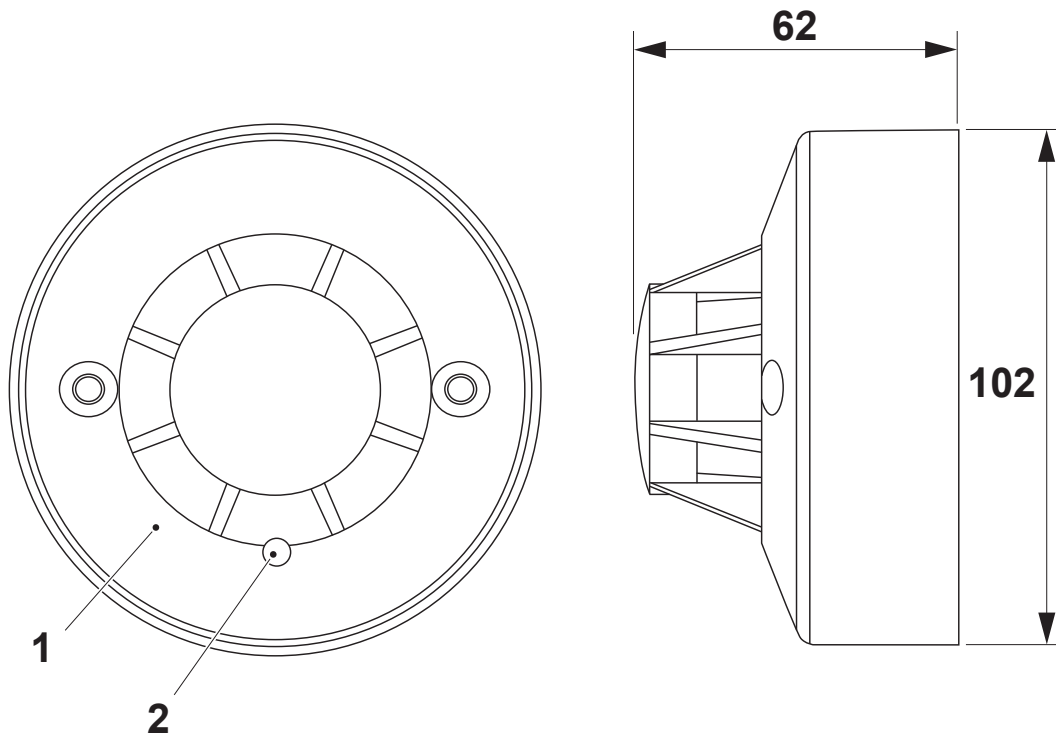

(Measure in mm)

- 1. Detector
- 2. LED

3.1.1. DETECTOR

The IS analog photoelectric smoke detector function is similar to the analog photoelectric smoke detector 4301 with scattered light (reflection of infrared light) used to detect smoke.

3.1.2. LED

The detector has one built-in LED to indicate that the detector has generated fire alarm.

3.2. IS ANALOG HEAT DETECTOR 2841

The intrinsically safe analog heat detector is used inside hazardous (Ex) areas. The detector is connected to the IS barrier unit 2842 via the IS COM line.

The detector can be mounted with or without the water-proof IS back-box 2843. The IP rating will be different depending on if the IP back-box 2843 is used or not.

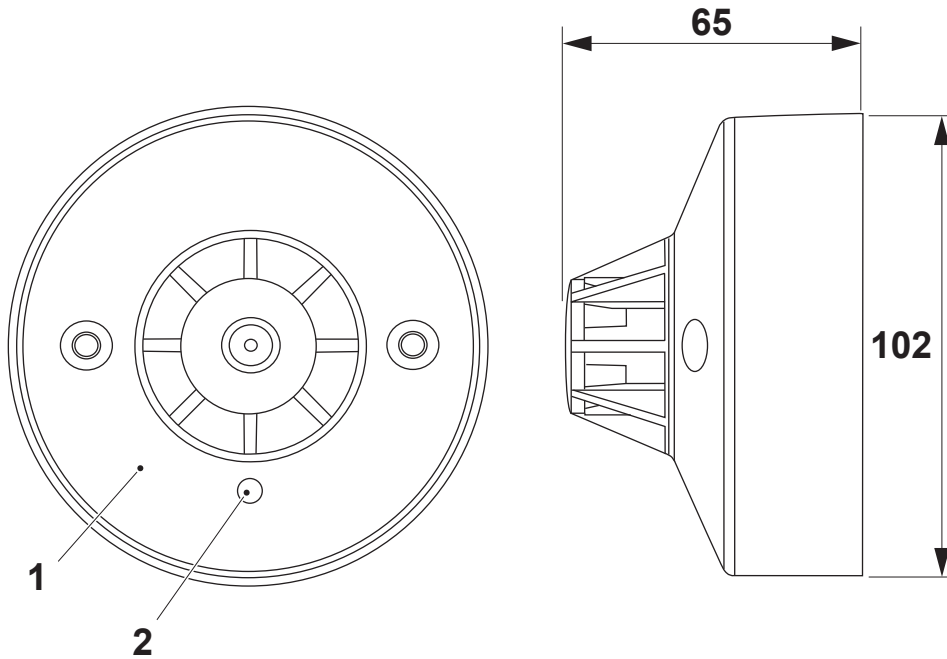

(Measure in mm)

1. Detector
2. LED

3.2.1. DETECTOR

The IS analog heat detector function is similar to the analog heat detector 3308/3309. The temperature is measured via a thermistor.

3.2.2. LED

The detector has one built-in LED to indicate that the detector has generated fire alarm.

3.3. IS SAFE BARRIER UNIT

The intrinsically safe barrier unit is used to connect analog addressable IS detectors to the COM loop.

One or more IS Barrier units 2842 are connected to the COM loop and the analog addressable IS detectors are connected to the IS COM line. On the COM loop can also be connected any type of COM loop units for the EBL system respectively but on the IS COM line can only the IS detectors 2840 and 2841 be connected.

Up to 20 IS detectors can be connected on the IS COM line, which is a single line with no return cable and no end-of-line device.

The unit has two connectors for COM loop in / out, two connectors for external power supply (24 V DC, 50 mA), and one connector (blue) for the IS COM line.

The barrier unit is mounted in a waterproof box, IP66/67.

The IS barrier unit shall be mounted outside the hazardous (Ex) area.

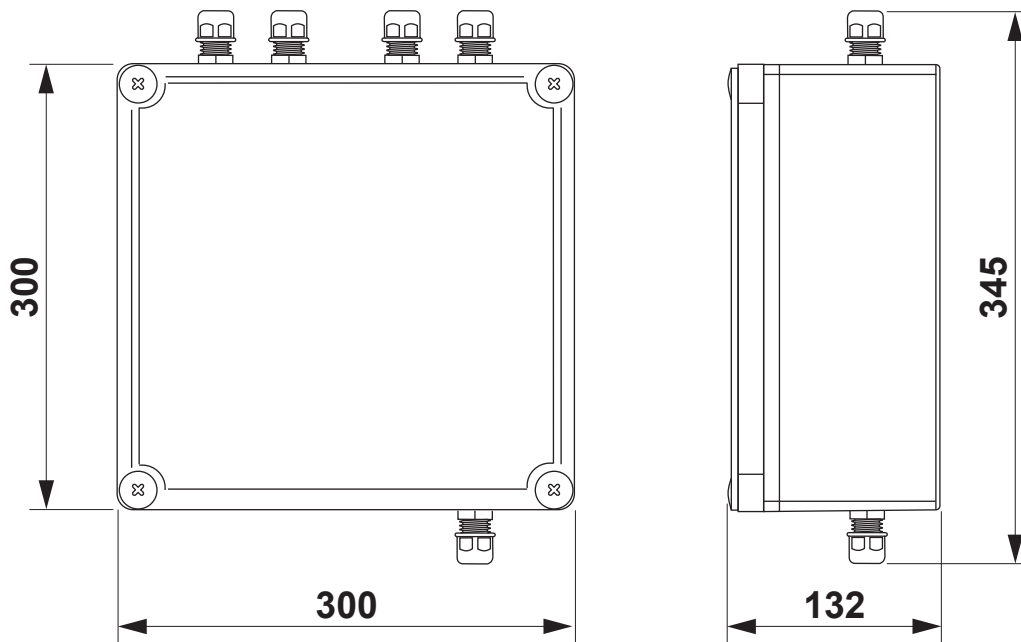

(Measure in mm)

3.3.1. POWER SUPPLY

The IS barrier unit's 24 V DC power supply is separated from the IS COM line with a transformer (DC / DC converter). The amount of power is limited.

Normal IS COM line voltage is 16 V DC (15 – 17.3 V).

Normal COM loop voltage is 24 V DC (12 – 30 V).

3.3.2. WATERPROOF BOX

Five cable glands are supplied.

3.4. IS BACK-BOX

The water-proof IS back-box 2843 can be used with the detectors 2840 and 2841 for higher IP rating. Two cable glands (PF $\frac{1}{2}$ ") are supplied.

3.5. RATING LABEL

Serial Number of type 2840 is indicated on the rating label. This indication method of Serial Number is the same regarding type 2841 & 2842.

Local certification number or mark can be displayed at the blank area, if any.

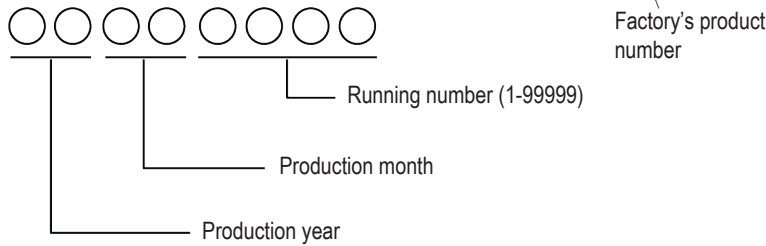
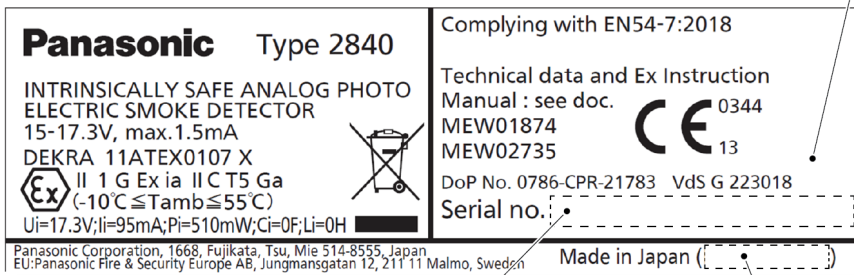

3.6. COMMUNICATION

The COM loop is separated from the IS COM line via an optocoupler.

The COM loop communication signals are transmitted to the IS COM line, via the IS barrier unit.

The IS COM line communication signals are put back to normal levels, via the IS barrier unit, and then transmitted to the CIE via the COM loop.

4. SET THE COM LOOP ADDRESS 2840 AND 2841

Each IS COM line unit has to have a unique COM loop address (001-253).

Set the address with the Address Setting Tool (4414 or 4414E). Use the connection cable with crocodile clips to connect the flying leads with the tool's SA & SB terminals.

The COM loop address and mode settings have to be done before the unit is connected to the COM loop.

The IS Barrier unit 2842 is connected to the COM loop but no address or programming is required.

5. SET THE MODE

Set the mode with the Address setting tool (4414 or 4414E) according to the table below.

5.1. COMPATIBILITY TABLE 2840

	Advanced mode	NORMAL mode	2330 mode	2312 mode
EBL512 G3	Not used	All versions	Not used	Not used
EBLOne	Not used	V ≥ 3.3	Not used	Not used
EBL128	Not used	All versions	Not used	Not used
Configured as:	-	4301	-	-

5.2. COMPATIBILITY TABLE 2841

	Advanced mode	NORMAL mode	2330 mode	2312 mode
EBL512 G3	Not used	All versions	Not used	Not used
EBLOne	Not used	V ≥ 3.3	Not used	Not used
EBL128	Not used	All versions	Not used	Not used
Configured as:	-	3308 / 3309	-	-

5.3. ALGORITHMS FOR 2840

The sensitivity, alarm level, etc. are depending on the selected alarm algorithm. The algorithm is programmed via EBLWin. Default is alarm algorithm **N-15**.

Select one of six smoke algorithms:

	Normal detection time (15 seconds)			Slow detection time (35 seconds)		
Algorithm	H-15	N-15	L-15	H-35	N-35	L-35
Smoke obscuration	2.4% High sensitivity	3.0% Normal sensitivity	3.6% Low sensitivity	2.4% High sensitivity	3.0% Normal sensitivity	3.6% Low sensitivity
Step value	X=8	X=10	X=12	X=4	X=5	X=6

The L-15, H-35, N-35 and L-35 algorithms might not fulfil the EN54-7 specifications.

5.4. ALGORITHMS FOR 2841

Algorithms for class A1, A2 S, and B S are used for detectors in NORMAL mode. The algorithm is programmed via EBLWin.

Select one of three algorithms (static response temperature range) for class:

Three Alarm Algorithms				
Static response temperature:	A1 54-65°C		A2 S 54-70°C	B S 69-85°C
	Rate of rise ≤ 4°C per minute	Rate of rise > 4°C per minute		
Fire Alarm	56°C	46°C	60°C	74°C

6. MOUNTING

6.1. IS ANALOG PHOTOELECTRIC SMOKE DETECTOR 2840

The intrinsically safe analog photoelectric smoke detector must be mounted in the ceiling, inside the Hazardous (Ex) area. The detector can be mounted with or without the water-proof IS back-box 2843. Screws are not supplied.

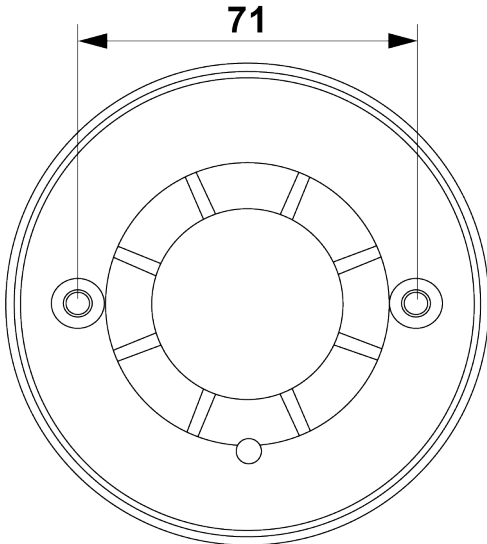

(Measure in mm)

6.2. IS ANALOG HEAT DETECTOR 2841

The intrinsically safe analog heat detector must be mounted in the ceiling, inside the Hazardous (Ex) area. The detector can be mounted with or without the water-proof IS back-box 2843.

Screws are not supplied.

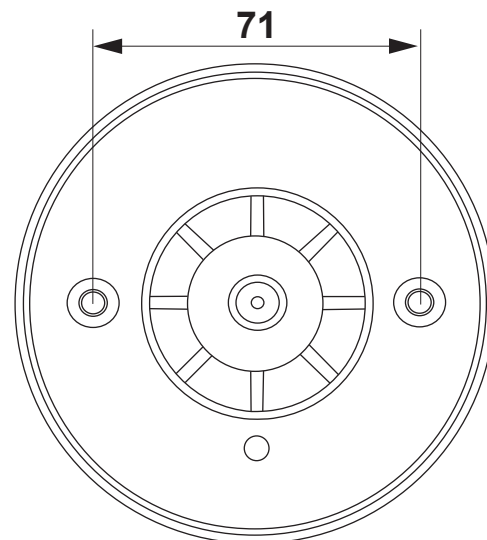

(Measure in mm)

6.3. IS BARRIER UNIT 2842

The IS barrier unit must be mounted on the wall, outside the hazardous (Ex) area.

The IS barrier unit is delivered with four mounting accessories that should be plugged in each corner of the box, see below. Type and length of mounting screws to be used is depending on the type of wall.

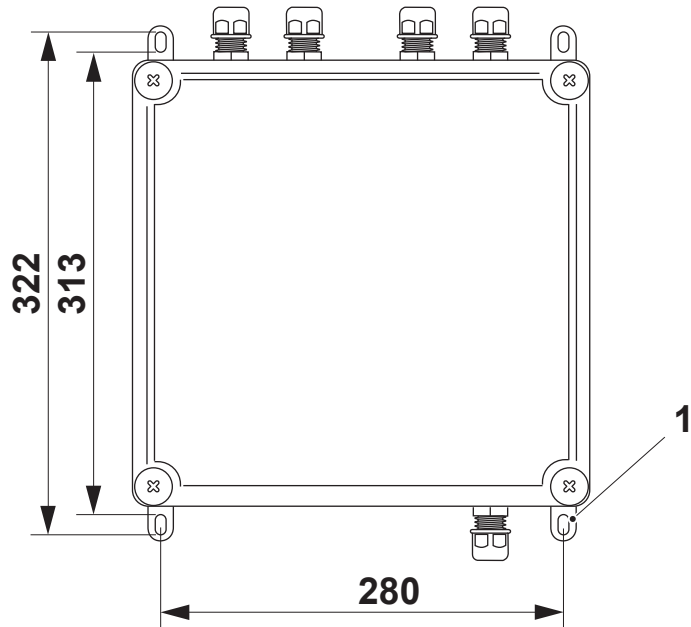

(Measure in mm)

1. Mounting accessories

6.4. IS BACK-BOX 2843

The IS detector 2840 or 2841 can be mounted with the water-proof IS back-box 2843. The IS back-box is mounted in the ceiling. Type of screws is depending on the type of ceiling.

Cut out the required number of knockouts and apply the cable gland before mounting the IS back-box in the ceiling. Tighten the cable glands firmly.

When the detector is mounted with the IS back-box 2843, the two supplied 25 mm M5 screws shall be used. The black rubber gasket has to be in correct position before the detector is mounted on the IS back-box.

Before the IS detector can be mounted on the IS back-box, the detector address and mode have to be set - see 4. SET THE COM LOOP ADDRESS 2840 AND 2841 on page 9.

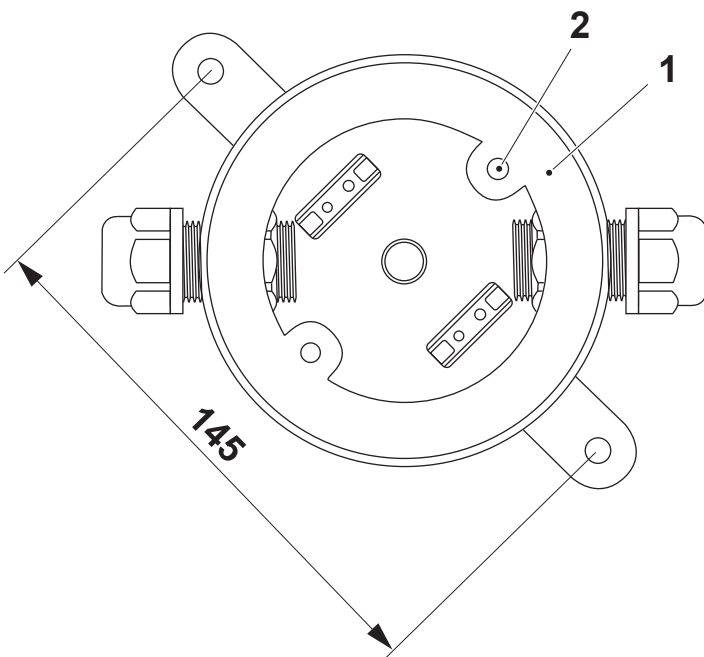

(Measure in mm)

1. Black rubber gasket
2. Tapped hole for detector mounting, $\text{Ø}=6.5$ mm

7. INSTALLATION AND WIRING

Screen wire termination is not provided.

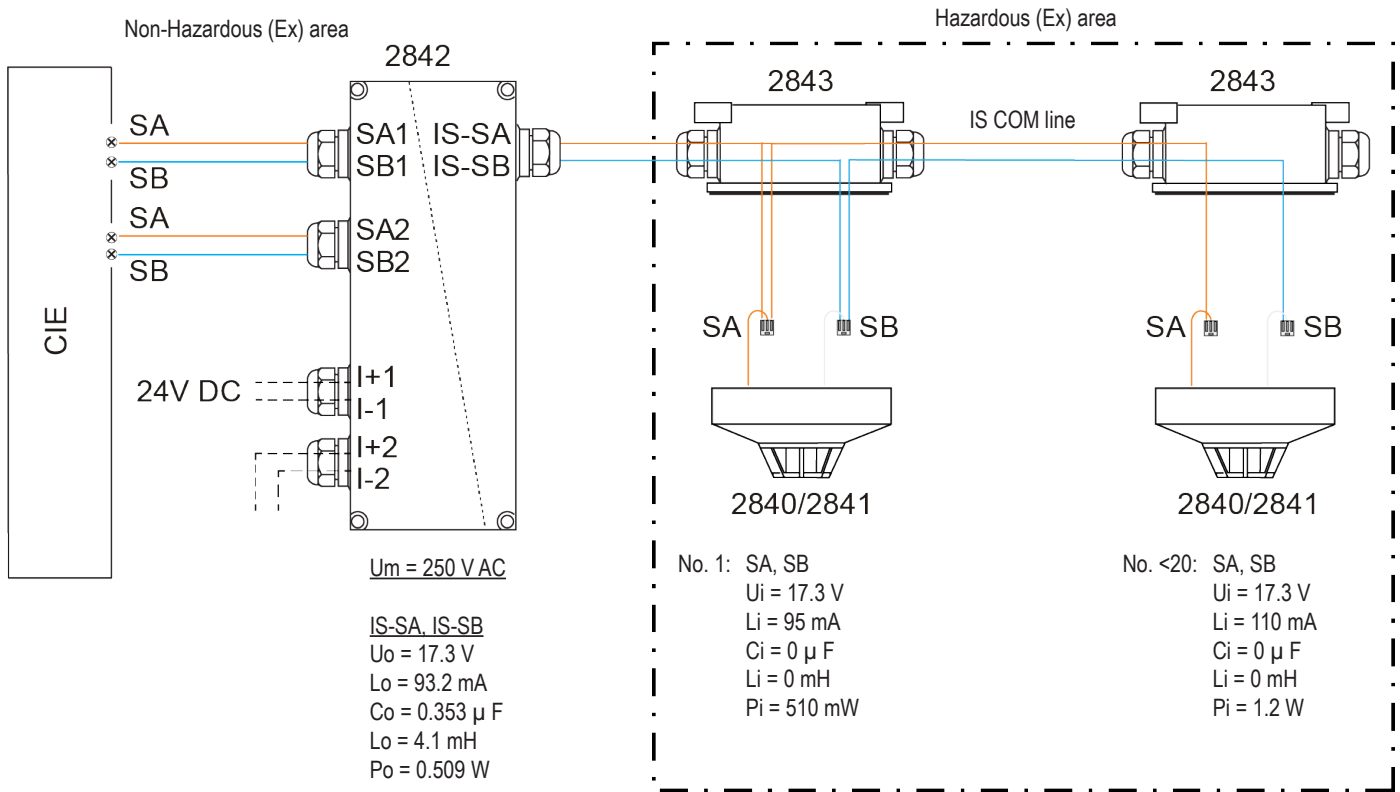

	Wire size (Min)	Wire size (Max)
2840	Ø 0.35 mm (0.08 mm ²)	Ø 0.6 mm (0.3 mm ²)
2841	Ø 0.35 mm (0.08 mm ²)	Ø 1.6 mm (2 mm ²)
2842 COM loop	Ø 0.6 mm (0.3 mm ²)	Ø 1.75 mm (2.5 mm ²)
2842 24V DC	Ø 0.6 mm (0.3 mm ²)	Ø 1.75 mm (2.5 mm ²)
2842 IS COM line	For example FKAR-PG 2 x 0.5 mm ² , blue	

The 24 V DC power supply is one cable in, and one cable out but only if there are more IS barrier units to be power supplied. Check that the "plug" (a blank round plate) is placed inside a not used cable gland. When required, insert the "out" cable into a cable gland and connect it to I+2 & I-2.

The cable gland close to the IS COM line connector has to be used for the IS COM line cable, which must not be close to any other cable in the IS back-box.

Regarding type 2840 and 2841 (incl. the IS-back box type 2843): Don't clean by rubbing or with solvents – electrostatic hazard. Don't dismantling Ex apparatus – it might impair Ex performance.

IS COM line:

Cable length maximum 500 meters.
 Conductive resistance: 40.4 Ω/km
 Capacitance: 0.13 µF/km
 Inductance: 0.7 mH/km

The detectors 2840 and 2841 has one 3-way "SA" fast connector (red wire) and one 3-way "SB" fast connector (white wire).



The 3-way fast connector: Pull up the orange lever 90 degrees, insert the wire with 10 mm stripped coating and push the lever down again.
 Wire area 0.08-2.5 mm² (AWG 28-12).

The hazardous area cable should have the following maximum parameters:

Group	Capacitance	Inductance	Inductance to resistance ratio
	µF	mH or	µH / ohm
IIC	0.353	3	74.3
IIB	2.06	13	321.8
IIA	8.5	30	742.6

7.1. CABLE GLAND

a) Insert the cables in the cable glands.

If the outer cable diameter is < 6 mm, insert the enclosed rubber tube before installation of the cable. If the outer cable diameter is ≥ 6 mm, do not use the enclosed rubber tube.

b) Tighten all cable glands with 4 Nm or more.

Cable gland data	MG16-06G for 2842	FGA21H-06 for 2843
Wire size min-max, circular cable	Ø 4.0-7.0 mm	Ø 4.3-6.4 mm
Wire size min-max, non-circular cable and metal-sheathed cable	Ø 4.0-7.0 mm	Ø 4.3-6.4 mm
Cable core size min-max, for compound filled glands	Ø 4.0-7.0 mm	Ø 4.3-6.4 mm
Mounting hole in 2842 / 2843	Ø 16.1-16.6 mm	Ø 21.4-21.6 mm

8. TEST MODE

8.1. TEST SMOKE DETECTOR (2840):

For information about how to set the detector in test mode, see Planning Instructions or Operating Instructions. It is possible to use test aerosol equipment for testing. For example “SOLO” or “Testifire”.

Coordinate with the site manager on test method.

8.2. TEST HEAT DETECTOR (2841):

For information about how to set the detector in test mode, see Planning Instructions or Operating Instructions. It is possible to use test equipment for testing, for example “SOLO” or “Testifire”.

Coordinate with the site manager on test method.

9. TECHNICAL DATA 2840

All current consumptions are valid by nominal voltage and by 25 °C.

Voltage: Allowed Normal	15 – 17,3V DC 16V DC
Current: Quiescent Active (incl. internal LED)	≤ 0.3 mA ≤ 1.5 mA
Address range	001-253
Address setting	With address setting tool
Short circuit isolator	No
Internal battery	No
Material	FR ABS and polycarbonate
Ambient temperature: Operating Storage	-10 to +55 °C -25 to +70 °C
Ambient humidity	Maximum 95 % RH (Non condensing)
Ingress protection rating	IP 22 IP 44 with IS back-box
Zone classification	Zone 0 / 1 / 2
ATEX	II 1 G Ex ia IIC T5 Ga
Size: Ø x H	Ø 102 x 62 mm
Weight	300 g
Colour	Grey (N8 Munsell colour code)

10. TECHNICAL DATA 2841

All current consumptions are valid by nominal voltage and by 25 °C.

Voltage: Allowed Normal	15 – 17,3V DC 16V DC
Current: Quiescent Active (incl. internal LED)	≤ 0.3 mA ≤ 1.5 mA
Address range	001-253
Address setting	With address setting tool
Short circuit isolator	No
Internal battery	No
Material	FR ABS and polycarbonate
Ambient temperature: Operating Storage	-10 to +XX ¹ °C -25 to +70 °C
Ambient humidity	Maximum 95 % RH (Non condensing)
Ingress protection rating	IP 22 IP 66/67 with IS back-box
Zone classification	Zone 0 / 1 / 2
ATEX	II 1 G Ex ia IIC T5 Ga
Size: Ø x H	Ø 102 x 65 mm
Weight	325 g
Colour	Grey (N8 Munsell colour code)

1) Depending on algorithm (A1, A2S & BS): XX = +50, +50 & +65 °C. Typical room temp.: +25, +25 & +40 °C.

11. TECHNICAL DATA 2842

All current consumptions are valid by nominal voltage and by 25 °C.

Voltage: Allowed Normal	12 – 30V DC 24V DC
Current: Quiescent Active (incl. internal LED)	≤ 10 mA ≤ 50 mA
Address range	N/A
Address setting	N/A
Short circuit isolator	No
Internal battery	No
Material	FR ABS and polycarbonate
Ambient temperature: Operating Storage	-10 to +55 °C -25 to +70 °C
Ambient humidity	Maximum 95 % RH (Non condensing)
Ingress protection rating	IP 66/67
Zone classification	Non-Hazardous Area
ATEX	II (1) G [Ex ia Ga] IIC
Size: H x W x D	300 x 300 x 132 mm
Weight	3100 g
Colour	Grey

12. APPROVALS

IS ANALOG PHOTOELECTRIC SMOKE DETECTOR 2840

Applicable directive/ Approval	Applicable standards	Notified body
CPR	EN54-7	VdS No. 0786-CPR-21783
VdS	EN54-7 VdS2344 VdS2543	VdS No. G223018
EMC	EN61000-6-3 (Emission) EN50130-4 (Immunity)	Self declaration
RoHS	EN IEC 63000	Self declaration
ATEX	EN IEC 60079-0:2018 EN60079-11:2012	DEKRA No. 11ATEX0107 X

IS ANALOG HEAT DETECTOR 2841

Applicable directive/ Approval	Applicable standards	Notified body
CPR	EN54-5	VdS No. 0786-CPR-21784
VdS	EN54-5 VdS2344 VdS2543	VdS No. G223019
EMC	EN61000-6-3 (Emission) EN50130-4 (Immunity)	Self declaration
RoHS	EN IEC 63000	Self declaration
ATEX	EN IEC 60079-0:2018 EN60079-11:2012	DEKRA No. 11ATEX0107 X

IS BARRIER UNIT 2842

Applicable directive/ Approval	Applicable standards	Notified body
CPR	EN54-18	VdS No. 0786-CPR-21785
EMC	EN61000-6-3 (Emission) EN50130-4 (Immunity)	Self declaration
RoHS	EN IEC 63000	Self declaration
ATEX	EN IEC 60079-0:2018 EN60079-11:2012	DEKRA No. 11ATEX0106



DOCUMENT NAME: TECHNICAL DESCRIPTION 2840-2843
DOCUMENT NUMBER: MEW01874 EN
DATE OF ISSUE: 2016-05-11
REV: 10
DATE OF REVISION: 2024-09-10

Panasonic Fire & Security Europe AB

Jungmansgatan 12
SE-211 11 Malmö
SE
Tel: +46 (0)40 697 70 00