



# MX25, MX40, and MX IP65

MX Emergency  
and Exit lights

Fire alarm solutions  
technical description

# Table of contents

<b>1.</b>	<b>INTRODUCTION</b>	<b>4</b>
<b>2.</b>	<b>ABBREVIATIONS</b>	<b>5</b>
<b>3.</b>	<b>GENERAL DESCRIPTION</b>	<b>6</b>
3.1.	EXIT LIGHT	7
3.1.1.	MX25 AND MX40	7
3.1.2.	EXIT LIGHT RED X	8
3.1.3.	PICTOGRAM	8
3.1.4.	EXIT LIGHT - ORDER FOLLOWING PARTS	9
3.2.	MX LIGHT	10
3.3.	LED	11
3.4.	INTERNAL BATTERIES	11
3.5.	MX OUTDOOR EMERGENCY LIGHT	12
3.6.	MX IP65 EXIT / EMERGENCY LIGHT	13
3.6.1.	EXIT OR EMERGENCY LIGHT MODE	14
3.7.	MX POWER BOX	15
3.7.1.	FUSES	16
3.7.2.	OUTPUT VOLTAGE	17
3.8.	PHASE MONITORING	18
<b>4.</b>	<b>TEST</b>	<b>19</b>
4.1.	COMMISSIONING TEST	19
4.2.	MONTHLY TEST	19
4.3.	ANNUAL TEST	19
<b>5.</b>	<b>ILLUMINATION</b>	<b>20</b>
5.1.	PLACEMENT EMERGENCY LIGHT	20
5.1.1.	MX LIGHT	21
5.1.2.	MX OUTDOOR	23
5.1.3.	MX IP65 EXIT / EMERGENCY LIGHT	24
5.2.	EMERGENCY LIGHTING CALCULATION	25
5.3.	PLACEMENT EXIT LIGHT	26
<b>6.</b>	<b>CONFIGURATION</b>	<b>27</b>
6.1.	EXIT LIGHT AND EMERGENCY LIGHT	27
6.1.1.	EXIT LIGHT MXE	27
6.1.2.	EXIT LIGHT (MXER) AND EMERGENCY LIGHT (MXL)	27
6.2.	4461 / 4462 FUSE FAULT	28
6.3.	4461 / 4462 PHASE MONITORING	29
6.4.	NO REPLY FAULT	29
<b>7.</b>	<b>SET THE COM LOOP ADDRESS</b>	<b>30</b>

<b>8.</b>	<b>SET THE MODE</b>	<b>30</b>
8.1.	COMPATIBILITY TABLE	30
<b>9.</b>	<b>ACCESSORIES AND SPARE PARTS</b>	<b>31</b>
9.1.	BATTERY CONNECTOR	31
9.2.	RECESS MOUNTING FRAME	31
9.3.	BALL PROTECTION	31
9.4.	TREADED ROD PLATE	32
<b>10.</b>	<b>MOUNTING</b>	<b>33</b>
10.1.	ANALOG BASE	33
10.2.	MOUNTING OF PICTOGRAM	33
10.3.	MX UNIT	34
10.4.	RED X MODEL	35
10.5.	MX OUTDOOR	36
10.6.	MX IP65 EXIT / EMERGENCY LIGHT	37
10.7.	MX POWER BOX	39
10.8.	SUPPLY LINE LENGTH	40
<b>11.</b>	<b>INSTALLATION AND WIRING</b>	<b>42</b>
11.1.	WIRING AS EXTENDED	43
11.2.	WIRING - DESCRIPTION POWER BOX	44
<b>12.</b>	<b>TECHNICAL DATA</b>	<b>45</b>
12.1.	OPERATING CONDITIONS	49
12.1.1.	1h back-up battery	49
12.1.2.	3h back-up battery	50
<b>13.</b>	<b>APPROVALS</b>	<b>51</b>

# 1. INTRODUCTION

This document describes:

- Exit signs MX25, MX40
- Exit sign MX25 red x, MX40 red x
- Safety Sign MX25 Fire Hydrant
- Emergency light MX Light
- MX Outdoor Emergency light
- MX IP65 Exit / Emergency light
- MX Power box

The document contains information about the product and instructions on how to mount and connect it.

## 2. ABBREVIATIONS

<b>CIE</b>	Control and indicating equipment	= control unit
<b>Lux</b>	Indicates how much light hits a surface. One lux is equal to one lumen per square meter (lux = lumens/m <sup>2</sup> )	
<b>Maintained</b>	Always on and will stay illuminated in the event of a power failure	
<b>Non-maintained</b>	Only comes on in the event of a power failure	

### 3. GENERAL DESCRIPTION

The exit lights are maintained, the lights are always on, both when the mains power fails and when it is present. Emergency lights are non-maintained, the lights are only on when the mains power fails or in case of emergency.

The exit lights also have an option for a red cross panel. The red cross is achieved by mounting a red cross panel onto the MX25 and MX40 pictogram.

The red cross on the exit light can be activated by a detector / zone in fire alarm state to indicate an unsafe exit direction.

Fire Hydrant (Pictogram) is a Fire Safety Sign designed to show location of fire fighting equipment. Available as MX25.

All MX units are fulfilling all the emergency light standards, EN 60598-2-22, EN 1838, EN 62034, and EN ISO 7010.

MX25, MX40, and MX Light units are IP41 rated, and are intended for indoor use in dry premises.

MX Outdoor and MX IP65 Exit / Emergency light are IP65 rated.

### 3.1. EXIT LIGHT

The entire exit light pictogram is illuminated in normal and emergency mode, with a viewing distance of 25 m or 40 m. This ensures that exit points and evacuation routes are fully lit at all times.

The exit light has an build-in back up battery that provides power to the exit light for one hour when the electricity goes out.

#### 3.1.1. MX25 AND MX40

The MX25 and MX40 pictogram can be one or two sided.

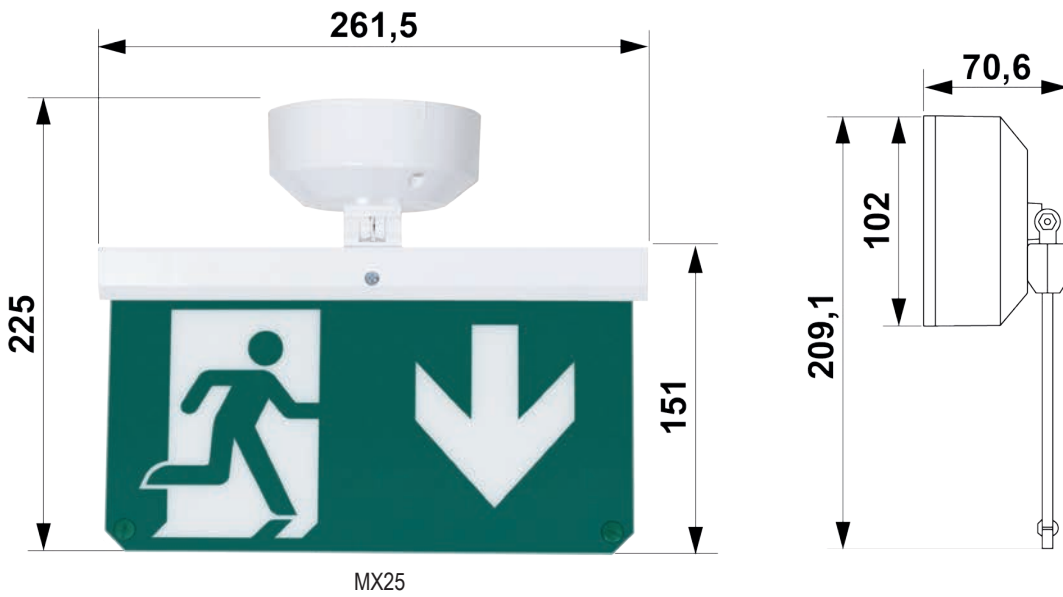

(Measure in mm)

### 3.1.2. EXIT LIGHT RED X

Exit light red x unit has an additional panel with a cross, that is mounted on top of the pictogram. The pictogram on an exit light with red x can only be one sided.

In EBLWin the unit is programmed as Exit light (MXER).

#### FIRE ALARM MXER UNIT

When an alarm point / zone is in fire alarm state, the activated control expression will turn on the red cross on the exit light, to show a blocked exit.

The red cross is deactivated when the fire alarm is reset via the CIE reset button.



### 3.1.3. PICTOGRAM

The exit light pictogram fulfil the requirements of EN 1838

- The minimum luminance in the green area is 2 cd/m<sup>2</sup>
- The contrast between the white and the green area is between 1:5 and 1:15
- Within the same colour, the contrast is less than 1:10

The pictogram for the exit light is ordered separately and are available in different directions. The pictogram can be one or two sided.



Pictogram HCP kit



970036 MX25 Pictogram (Hydrant)



### 3.1.4. EXIT LIGHT - ORDER FOLLOWING PARTS

For a complete exit light you need an analog base 3312FLW / 3312W, a mounting profile, and a pictogram. For the MX25/40 red x units you also need the red cross panel.

#### Exit lights with 1 hour backup time

	MX25	MX25 Red X	MX40	MX40 Red X
Mounting profile:	825100	825101	840100	840101
Red cross panel	-	970020	-	970021
Analog base	3312FLW/3312W	3312FLW/3312W	3312FLW/3312W	3312FLW/3312W
Pictogram	See "3.1.3. PICTOGRAM" on page 8 and pricelist for article numbers			

#### Exit lights with 3 hour backup time

	MX25	MX25 Red X	MX25 BLACK	MX25 Red X BLACK	MX40	MX40 Red X	MX40 BLACK	MX40Red X BLACK
Mounting profile:	825300	825301	825302	825303	840300	840301	840302	840303
Red cross panel	-	970020	-	970020	-	970021	-	970021
Analog base	3312FLW/3312W	3312FLW/3312W	930040*	930040*	3312FLW/3312W	3312FLW/3312W	930040*	930040*
Pictogram	See "3.1.3. PICTOGRAM" on page 8 and pricelist for article numbers							

\* Black base for EMEX



## 3.2. MX LIGHT

MX Light emergency lights are non-maintained and the light come on in the event of a mains power failure or emergency situation, making sure all emergency evacuation routes are clearly illuminated.

During normal operation the MX Light unit take power from the mains supply, but when switching to emergency mode the unit take power from a build-in back up battery.

The emergency light can be activated with, control expression, phase monitoring, or by a fire alarm.

The emergency lights are available in two different variants:

MX Light R: is used for open areas where emergency light is required. Light R has a round symmetric light image and will illuminate the floor with 0.5 to 1 lux.

MX Light C: is used for corridors or evacuation routes, and will illuminate the floor with 0.5 to 5 lux. Light C has an asymmetrical light image

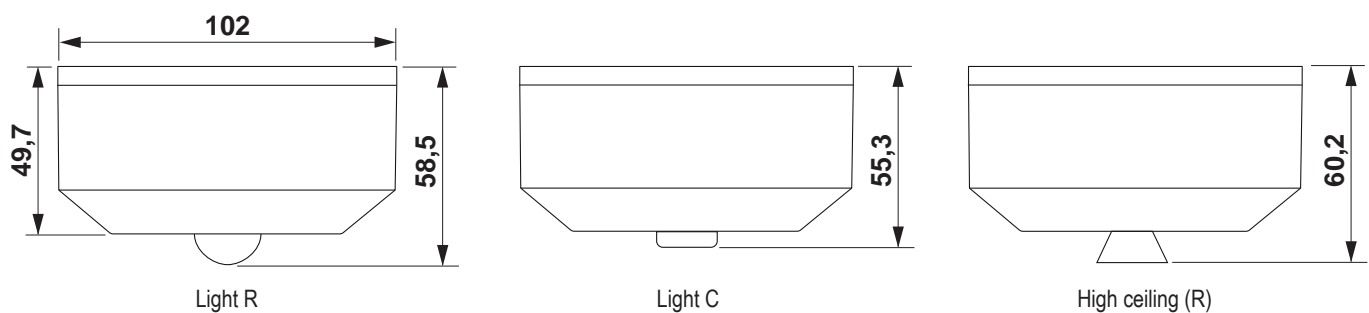

(Measure in mm)

### 3.3. LED

MX units connected to an analog base 3312FLW / 3312W, has one LED to indicate the unit status.



LED	State of the unit
Solid green	Operating normally
Blinking green	Performing commissioning test
Solid red	Faulty LED luminaire
Blinking red	Faulty battery or failed duration test

*If the LED luminaire is faulty, the entire unit needs to be changed. The LED has a normal operational life time of more than 10 years.*

### 3.4. INTERNAL BATTERIES

The MX units are back-up powered by internal batteries, see [“9.1. BATTERY CONNECTOR” on page 31](#).

MX units with 1 hour backup time are backed-up powered by one 1.2V NiMh battery.

MX units with 3 hour backup time are backed-up powered by a Nimh 2.4V battery pack, type HHR-210AH.

MX IP65 units (3 hour backup time) are backed-up powered by a Nimh 2.4V battery pack, type BK-220SCHU.

The batteries has three to six years of service life used in normal operation. A technical warning is activated in the CIE when the batteries needs to be replaced.

### 3.5. MX OUTDOOR EMERGENCY LIGHT

MX Outdoor are IP65 rated and luminaire is designed specifically to withstand harsh conditions such as parking halls and outdoor environment.

MX Outdoor Emergency Light is non-maintained and the light come on in the event of a mains power failure or emergency situation, making sure the emergency evacuation exit is clearly illuminated.

During normal operation the MX Outdoor Emergency Light take power from the mains supply, but when switching to emergency mode the unit take power from a build-in back up battery with 3 hour back up time.

MX Outdoor Emergency Light always consists of two units: the luminaire and a separated electronic unit. Between the luminaire and electronic unit includes a 2 meter fire-proof cable.

The luminaire is designed for surface mounted on wall or ceiling.

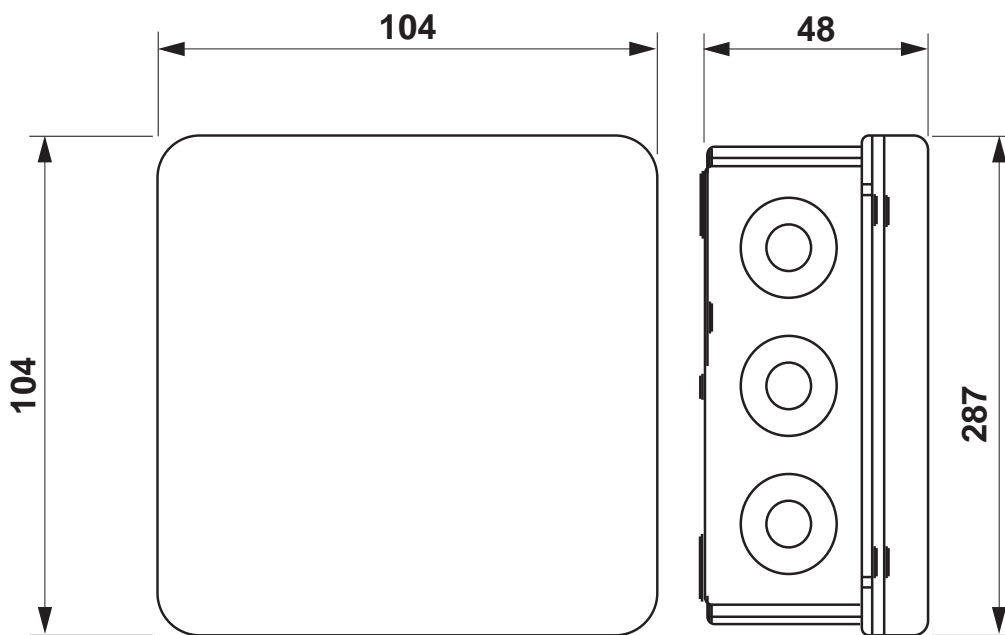

(Measure in mm)

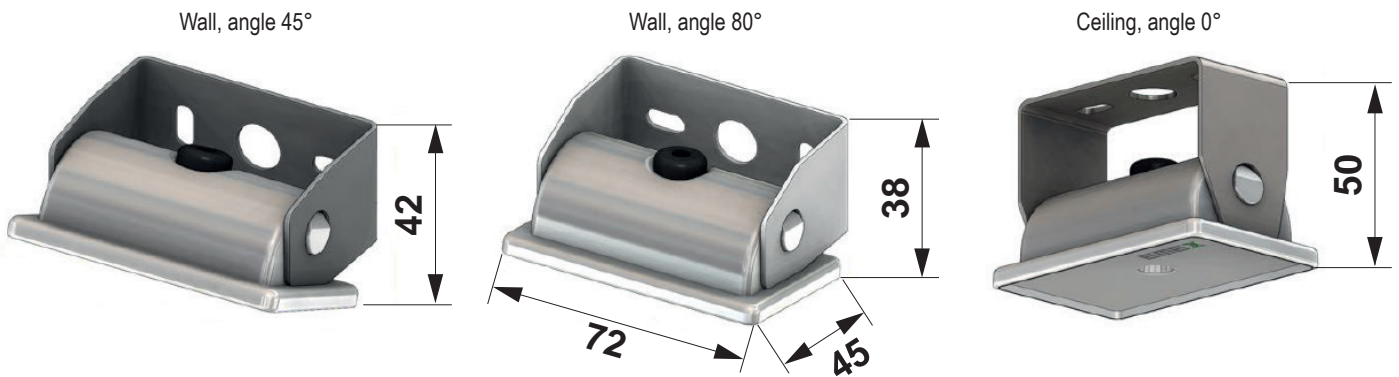

### 3.6. MX IP65 EXIT / EMERGENCY LIGHT

MX IP65 Exit / Emergency light is designed specifically to withstand harsh conditions such as parking halls and outdoor environment. The unit can be used both as exit light and emergency light, a dip switch is used to select the mode of the unit.

When used as exit sign, the entire MX IP65 Exit / Emergency light pictogram is illuminated in normal and emergency mode, with a viewing distance of 25 m. This ensures that exit points and evacuation routes are fully lit at all times.

The pictogram can be one or two sided. As an accessory (part number 930016, MX IP65 Double sided cover) is a double sided cover available.

When used as an emergency light it is non-maintained and the light come on in the event of a mains power failure or emergency situation.

The MX IP65 Exit / Emergency light has an build-in back up battery that provides power to the exit light for three hours when the electricity goes out.

Can be mounted on the ceiling or on the wall.

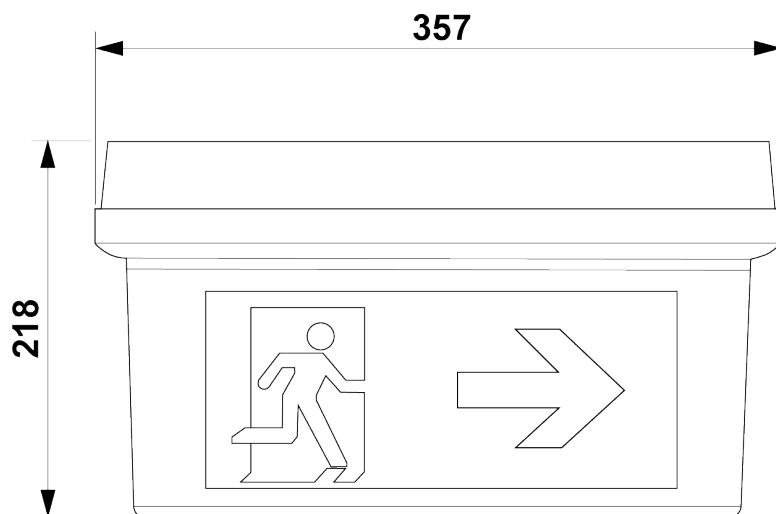
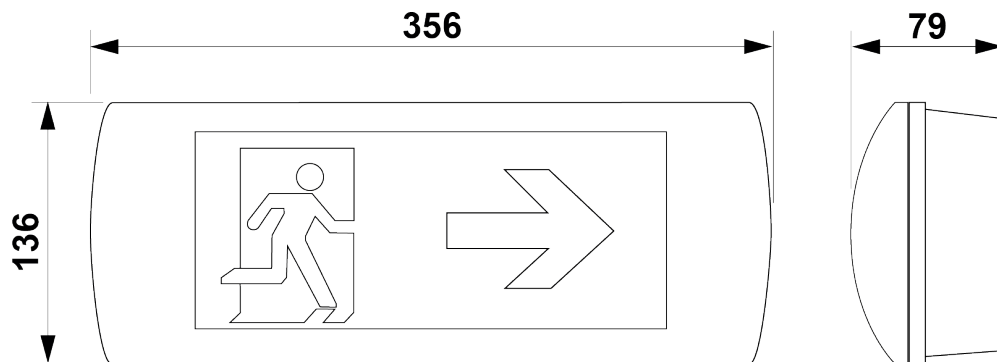

Double sided cover

(Measure in mm)

### 3.6.1. EXIT OR EMERGENCY LIGHT MODE

The MX IP65 Exit / Emergency light is factory set to the Emergency light mode. Use the dip switch, see arrow, to choose between Exit sign or Emergency light mode.

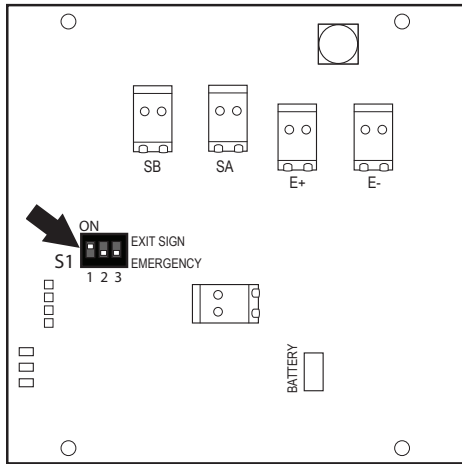

Setting for Emergency light (Switch 1 ON)

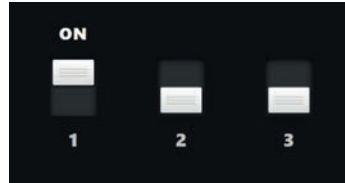

Setting for Exit light (All switches ON)



#### DIP Switch settings:

1. Battery: OFF=1h ON=3h. For IP65 product it shall always be ON.
2. OFF = Emergency light. ON = Exit light
3. High current for LED. OFF for Emergency light. ON for Exit light.

### 3.7. MX POWER BOX

The MX Power box consists of the rectifier and a connection board.

MX Power box is intended to be used as power supply for the exit lights and emergency lights.

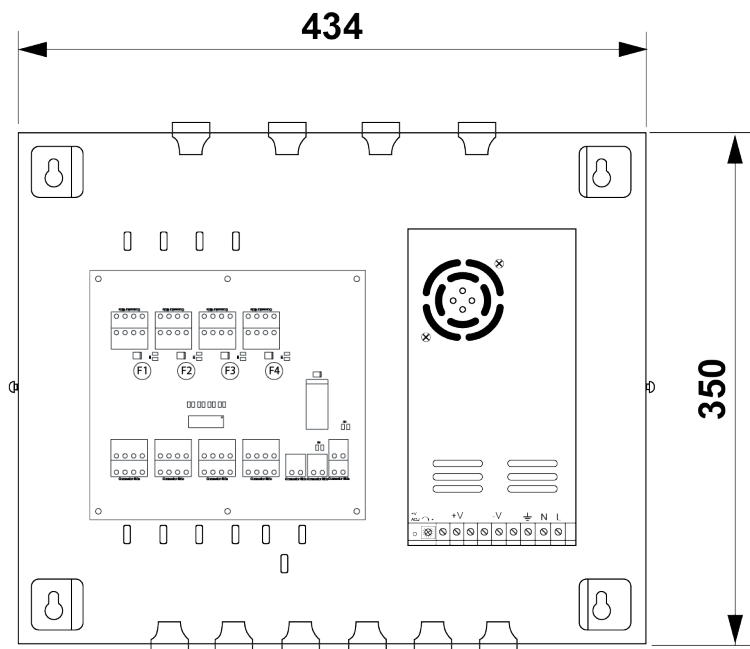

(Measure in mm)

MX power box provides supply line to exit and emergency lights located on up to four COM-loops.

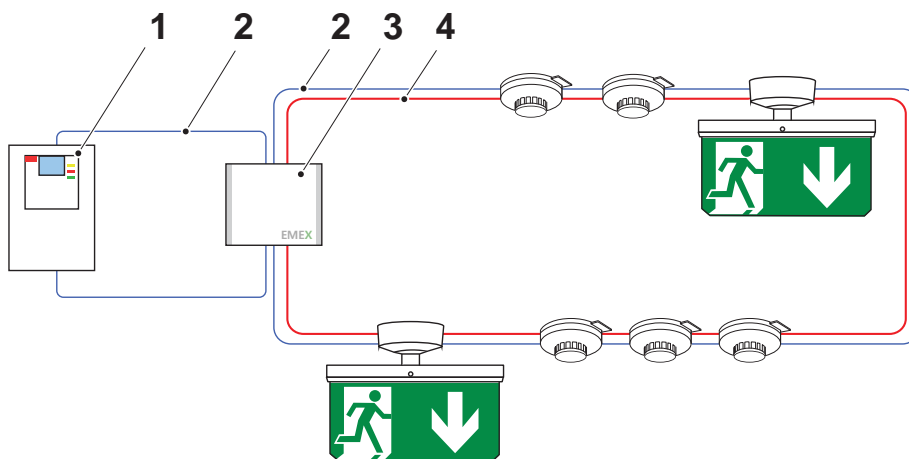

- 1. Control unit
- 2. COM loop
- 3. Power box
- 4. Supply line, 24 V

### 3.7.1. FUSES

The connection board has separate fuse holders for each COM-loop. TR5 3.15A -fuses are supported. Each COM-loop also has a green LED for indicating a faulty fuse (Solid green = operating normally). 24V IN has LED for indicating connected power and TEST SW has LED for indicating activated test relay.

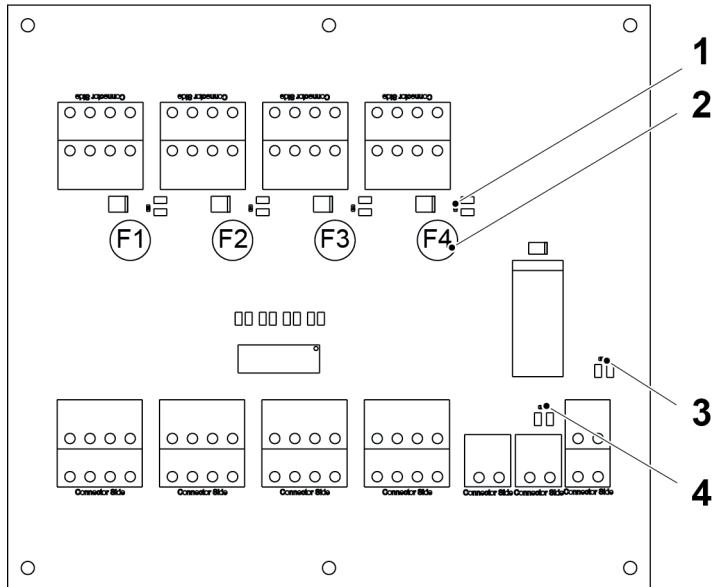

1. COM-loop LED
2. Fuse
3. 24V IN LED
4. TEST LED

### 3.7.2. OUTPUT VOLTAGE

MX Power box output voltage can be adjusted using the adjusting screw on the rectifier. For longer COM-loops it is recommended to set the output voltage to maximum voltage of about 31.5 V.

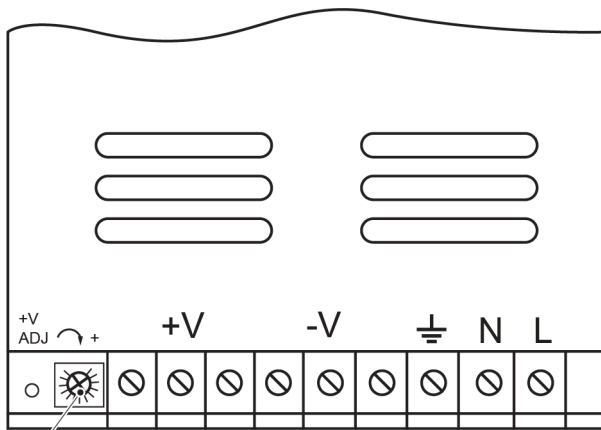

**1**

1) Adjusting screw

Input	Voltage	88-264 V AC (Universal input 110/230VAC)
Output	Voltage	26-31.5 V DC
	Current	Max 11.9 A
	Power	Max 320 W

### 3.8. PHASE MONITORING

The emergency lights continuously monitor the voltage of the supply line and enters emergency mode if the voltage falls below 12 V. However, the building lights may be connected to another phase than the power supply for the emergency lights. To make sure that the emergency lights are activated in case of any phase fault, a phase monitoring device should be used.

One phase monitoring device is needed for each power system. Connect one I/O unit 4461 / 4462 , to the COM loop, with a phase monitoring device connected to the monitored input Z/In0.

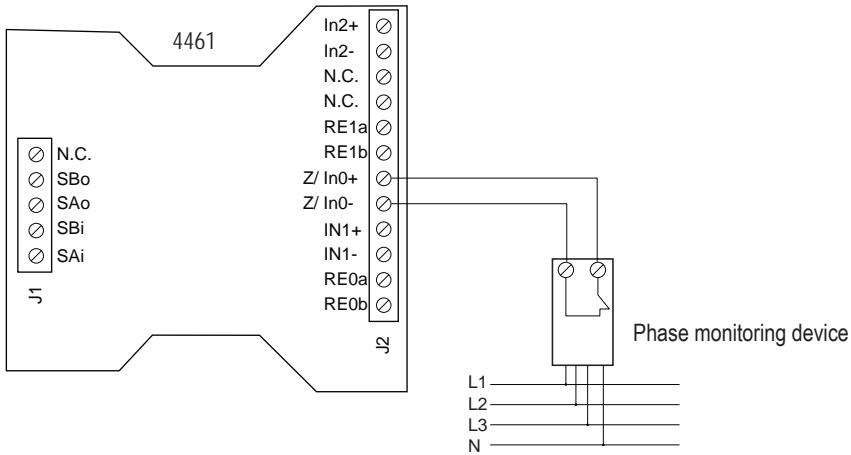

## 4. TEST

### 4.1. COMMISSIONING TEST

Commissioning test consists of duration test, battery test, and a LED luminaire test. After first time powering on the unit or after emergency mode which caused the unit to turn off, the unit starts to perform a commissioning test.

During the commissioning test green indicator light is blinking. After passing the commissioning test without errors green indicator light is solid.

If the duration test or the battery test failed, it is indicated with a blinking red indicator light and an activated technical warning for the failed test.

If the LED luminaire test failed, it is indicated with a solid red indicator light and an activated technical warning.

### 4.2. MONTHLY TEST

MX units has an automatic test system and a functional test is done monthly to ensure proper functionality of the LED luminaire and the battery. When the functional test starts, the unit switches from using supply line power to battery power and performs LED luminaire test and battery test. The functional test last only for a couple of seconds.

When the test mode is ended, a status message is logged in the Exit light event log that can be retrieved in EBLWin.

At the end of the functional test, failed LED luminaire test is indicated with a solid red indicator light and an activated technical warning, and a failed battery test is indicated with a blinking red indicator light and an activated technical warning.

### 4.3. ANNUAL TEST

Since the battery capacity deteriorates over the years, a duration test is done at least once a year.

When the duration test starts, the MX unit switches from using supply line power to battery power and turns on the LED luminaire. The device is tested for its full rated operating time (1 hour). After the duration test, the unit returns to normal mode and starts the battery charging process.

After one hour, when the duration test is ended, a message is is logged in the Exit light event log that can be retrieved in EBLWin.

If during the duration test, the unit does not fulfill its rated operating time, a failed duration test is indicated with a blinking red indicator light and an activated technical warning.

See "[3.3. LED](#)" on page 11.

## 5. ILLUMINATION

In an evacuation situation, it is important that there is enough light in the room and that exit lights are placed so that people can locate, as well as move to, an evacuation route.

### 5.1. PLACEMENT EMERGENCY LIGHT

The emergency lights must be positioned so that a safe evacuation can take place and that all possible obstacles along the evacuation route can be detected. The purpose of emergency lighting is not only to be able to locate, and move to an evacuation route, it is also important that the emergency lighting ensures that, First Aid stations, fire-fighting equipment, fire alarm buttons, etc. can be easily located.

Lux: the amount of light that is cast on the surface is called illuminance, which is measured in lux. This can be thought of as light intensity within a specific area.

Open areas: Any floor area larger than 60 m<sup>2</sup>, or less if there are additional risks, for example that many people can stay, is an open area requiring emergency lighting. In open areas, illumination of 0.5 lux minimum should be provided, apart from 0.5 m closest to the wall.

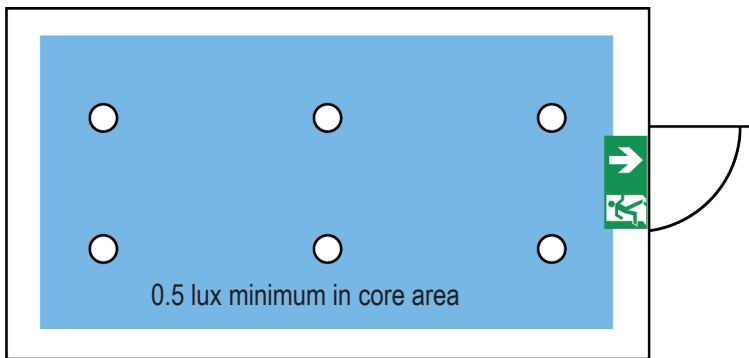

○ = Emergency light

Evacuation route: The illuminance required on the floor of a corridor-like evacuation route, up to 2 m wide, should be a minimum of 1 lux along the center line, and half of the width of the central evacuation route shall have a minimum of 0.5 lux.

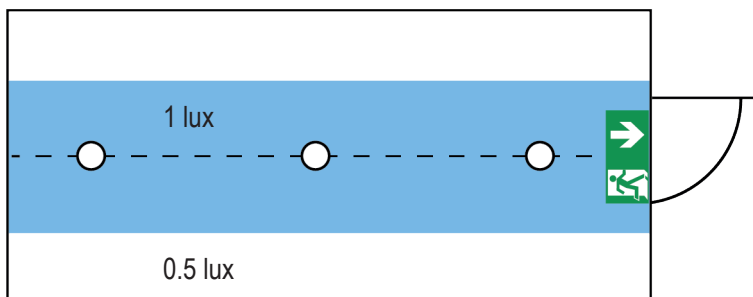

○ = Emergency light

High risk areas: Some high risk areas require more illuminance, for example fire-fighting equipment, stairs, and other level differences in the evacuation routes, and must be illuminated with at least 5 lux.

### 5.1.1. MX LIGHT

The tables below are a recommended illumination of the emergency lights. To be sure that the illuminance in the event of a mains power failure / fire alarm will be satisfactory, lighting calculations must be performed, see chapter “5.2. EMERGENCY LIGHTING CALCULATION” on page 25.

*National regulations must be followed when calculating the amount of lux needed.*

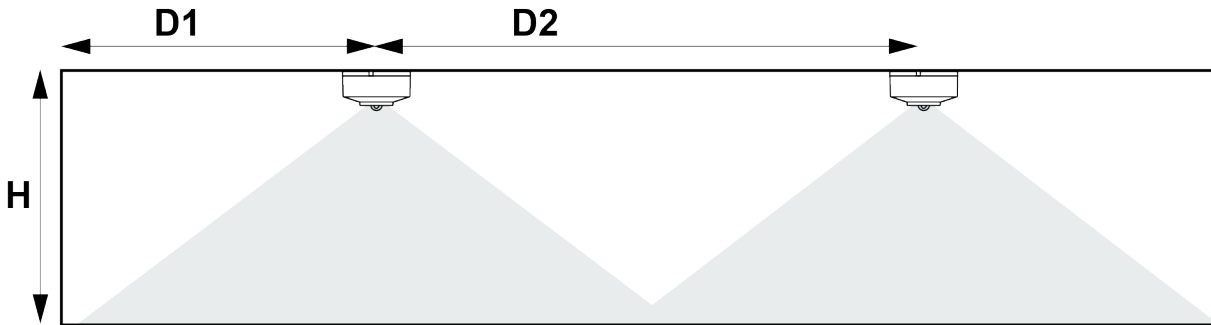

*Each part of the evacuation route and each open surface must be illuminated by two lights (emergency light or exit light), in order to avoid total darkness in the event of a luminaire failure.*

Light R, 0.5 lux

Height (m)	D1 (m)	D2 (m)
2.5	4.4	9.7
3	4.9	11
3.5	5.3	12.2
4	5.5	13.4
4.5	5.6	14.4
5	5.4	14.8
5.5	5.3	13.2

Light C, 1 lux

Height (m)	D1 (m)	D2 (m)
2.5	8.7	19.4
3	8.7	20.2
3.5	8.3	20.5
4	8.2	19.8
4.5	8.1	19.3
5	7.5	18.5
5.5	4.8	17.8

Light R, 5 lux

Height (m)	D1 (m)	D2 (m)
2.5	3	8
3	2.5	9
4	2	8

Light C, 5 lux

Height (m)	D1 (m)	D2 (m)
2.5	5	11
3	5.5	12
4	6	16
5	3	14

Light High ceiling (R), 0.5 lux

Height (m)	D1 (m)	D2 (m)
8	5.6	11
9	5.6	11.5
10	6	12
11	6	12
12	6	12
13	6	13
14	6	12
15	6	12

Light High ceiling (R), 1 lux

Height (m)	D1 (m)	D2 (m)
7	4	8.5
8	4.5	8.5
9	4.5	9
10	4.5	9
11	4.3	8.6
12	4.2	8.5
13	4	7.8
14	3.6	7
15	3.6	7

## 5.1.2. MX OUTDOOR

Mounting height from 2 to 7.5 meters.

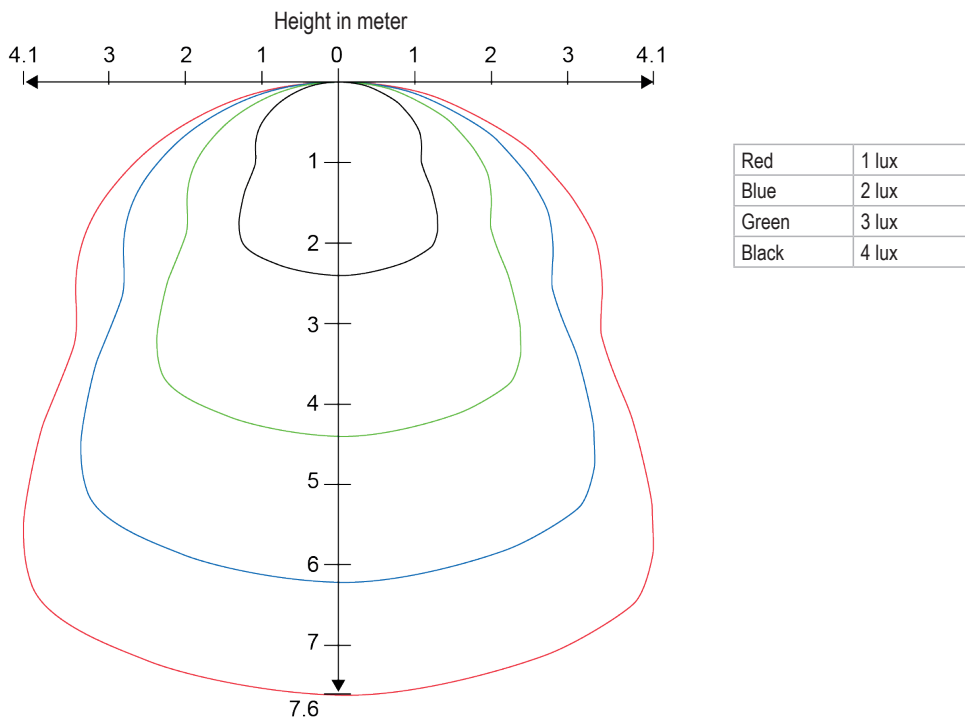

The illustration is an example of how the evacuation exit may be illuminated with an MX Outdoor emergency light mounted above the door.

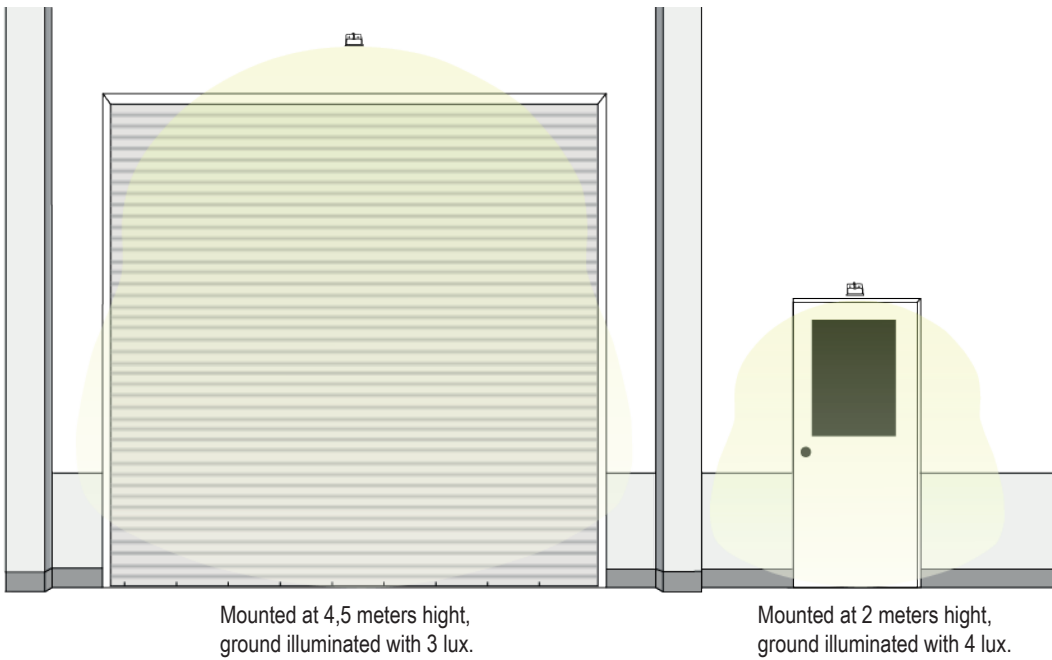

### 5.1.3. MX IP65 EXIT / EMERGENCY LIGHT

MX IP65 Exit / Emergency light, 0.5 lux

Height (m)	D1 (m)	D2 (m)
2.5	5.0	10
3	5.5	11
4	6.5	12
5	6.5	13
6	7	14
7	6.5	13
8	6.5	13

MX IP65 Exit / Emergency light, 1 lux

Height (m)	D1 (m)	D2 (m)
2.5	4.0	8.7
3	4.5	9.5
4	5	9.5
5	5	10
6	5	9.5
7	4.5	9
8	3.5	7.5

## 5.2. EMERGENCY LIGHTING CALCULATION

A photometric data file (IES file) is a plain text file that contain data on light for architectural programs that can simulate light. Plan, calculate, and visualize the emergency light pattern for entire buildings or individual rooms in for example DIALux lighting design software.

IES files for the emergency lights can be downloaded from <https://www.panasonic-fire-security.com/>.

Example - Using the DIALux software

All parameters are not defined in a IES file or LDT file, and they need to be adjusted or changed in Dialux.

IES files don't include information of color, because that information can't be transferred to IES format.

The user needs to know Information of lamp type and add it to Dialux.

Most of these parameters, not included in the IES file, has no critical importance for calculation results such as illuminance. But they will be shown in the datasheet of the lamp when exporting results.

The IES files are quite general, since the files are used in many different types of softwares.

Data for both Round and Corridor:

156lm

CCT 5000k

CRI 86

Power 1W

Below is an example with Round.IES, where the lamp type is changed, lumens, CCT and CRI:

The screenshot shows the 'Lamps' configuration window in DIALux. It is divided into several sections:

- Active equipment:** Shows 'Round' as the active equipment with a fitting of '1 x Round'.
- Properties:** Name: Round, Luminous flux: 300 lm, Power: 0.0 W, Lamp type: LED.
- Colorimetric data for documentation:** CCT: 5470 K, CRI: 86.
- Colorimetric data:** Spectrum graph for 5470K and a table of R1-R14 values.

R1: 86	R2: 90	R3: 91	R4: 87	Ra 86
R5: 86	R6: 85	R7: 89	R8: 76	
R9: 31	R10: 75	R11: 87	R12: 68	R13: 87
				R14: 95

## 5.3. PLACEMENT EXIT LIGHT

In open areas, exit lights must be provided for safe movement to the evacuation route.

In the evacuation routes, there must also be an exit light above each door and at each change of direction.

The exit lights should be positioned so that each sign is always within a readable viewing distance and each sign shall be located so that it is visible to confirm the correct route at every intersection or change of direction.

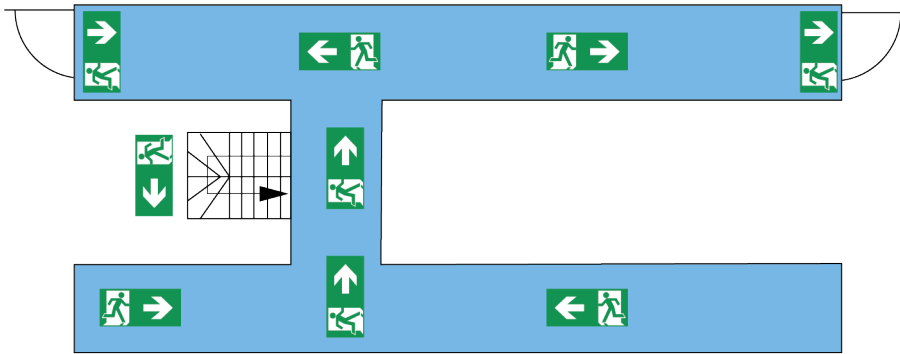

The height of the exit light pictogram determines the reading distance the luminaires are approved for. To calculate the maximum viewing distance of the exit light, use the following formula:

$$D = S \times P$$

S = Constant 200 for an internally illuminated sign.

Example:

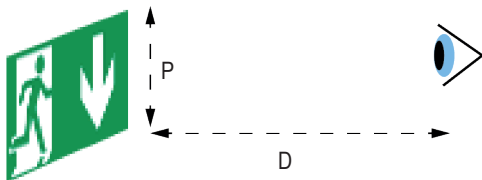

*In rooms where there are many other signs (billboards and other points of light that attract attention) it can be recommended to oversize the pictogram's sizes.*

## 6. CONFIGURATION

The MX units needs to be manually added into the configuration. A control expression can be programmed to activate the emergency lights or the red cross on the MXER unit.

*All technical warnings must have unique names.*

### 6.1. EXIT LIGHT AND EMERGENCY LIGHT

In the Exit light / emergency light properties window, set the following:

#### 6.1.1. EXIT LIGHT MXE

- Technical address
- Type 'Exit light (MXE)' is set as default. Edit if required
- Technical warning: Choose 'Show on main screen', 'Latched', or 'Buzzer'. Edit if required

#### 6.1.2. EXIT LIGHT (MXER) AND EMERGENCY LIGHT (MXL)

- Technical address
- Type: Select 'Exit light (MXER)' or 'Emergency light (MXL)'
- Technical warning: Choose 'Show on main screen', 'Latched', 'Buzzer', or "Use technical warning for fault".
- Control expression (one or more trigger conditions)

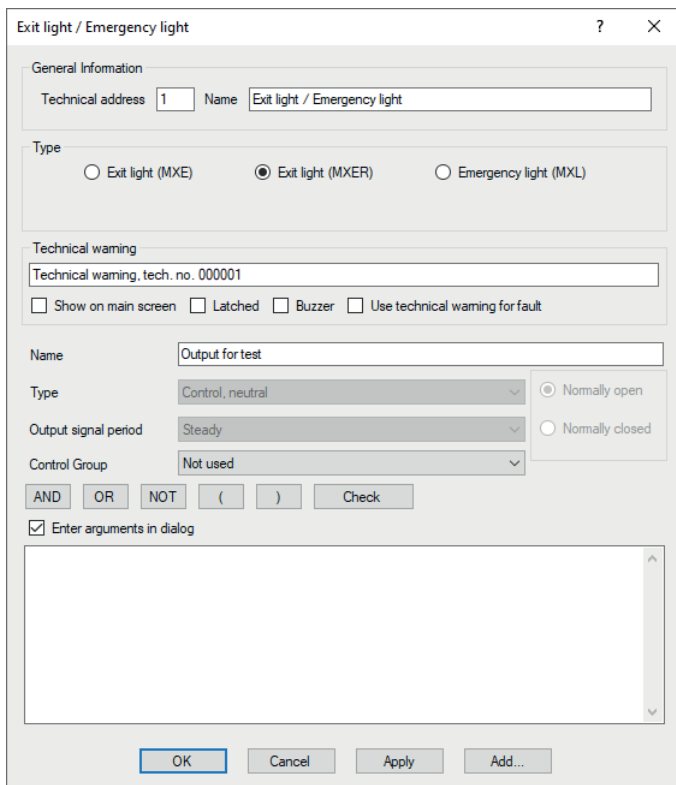

## 6.2. 4461 / 4462 FUSE FAULT

4461 / 4462 can be programmed to “Alarm at fuse fault”. The 4461 / 4462 input has to be programmed with a trigger condition and to be normally closed (NC).

The screenshot shows a software window titled "4461 I/O unit with isolator". It has a "General Information" tab and a "Short circuit isolator" sub-tab. The "Technical address" is set to "1" and the "Name" is "I/O 4461 with isolator". Below this, there are tabs for "Input 0", "Input 1", "Input 2", "Output 0", and "Output 1". The "Input 0" tab is active, showing the following configuration:

- Name:** Input 0
- Type:** Technical warning
- Logic:**
  - Normally open
  - Normally closed
- Supervised
- Technical warning:**
  - Text:** Fuse fault Power box XX
  - Show on main screen
  - Latched
  - Buzzer

At the bottom of the window are buttons for "OK", "Cancel", "Apply", and "Add...".

### 6.3. 4461 / 4462 PHASE MONITORING

4461 / 4462 can be programmed to “Alarm at phase fault”. The 4461 / 4462 input has to be programmed with a trigger condition and to be normally closed (NC). The technical warning can be used to activate the emergency lights or a control unit output.

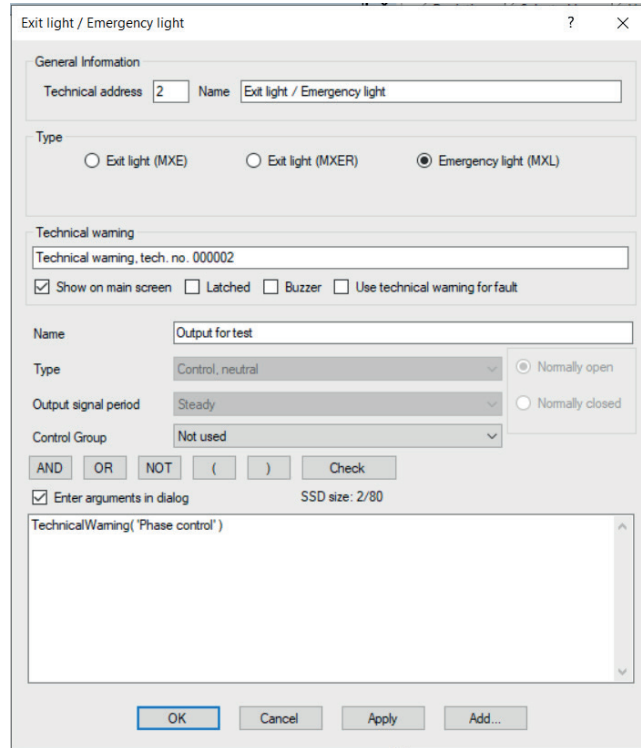
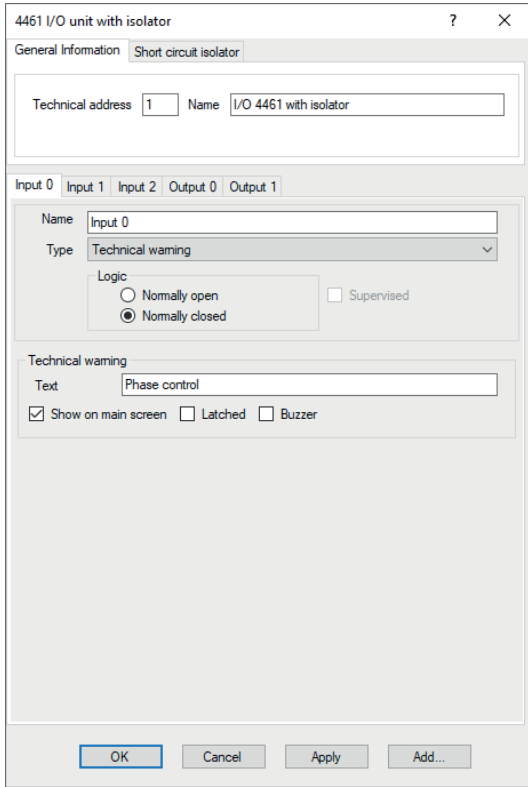

### 6.4. NO REPLY FAULT

Normally, if the control unit can not communicate with the exit light a “No reply fault” is detected. For example if an exit light is removed. However there is also a possibility to use the technical warning instead of the fault message. Edit if required.

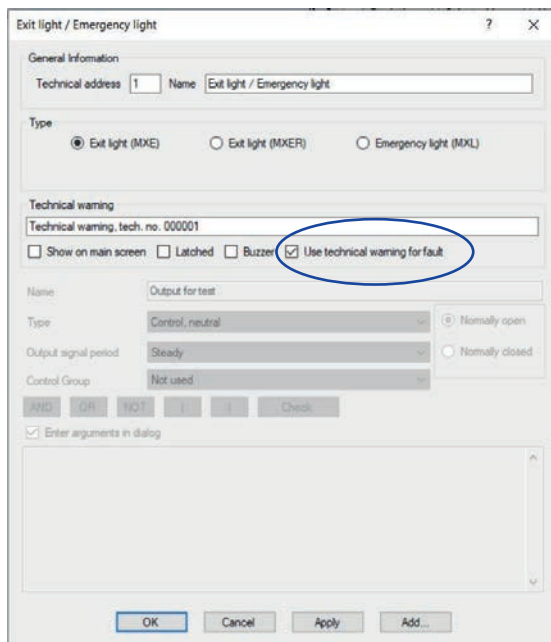

## 7. SET THE COM LOOP ADDRESS

Each COM loop unit has to have a unique COM loop address (001-253).  
Set the address with the Address Setting Tool (4414).

*The COM loop address and mode settings have to be done before the unit is connected to the COM loop.*

## 8. SET THE MODE

Set the mode with the Address setting tool (4414).

Set the mode to NORMAL.

### 8.1. COMPATIBILITY TABLE

	Advance mode	NORMAL mode	2330 mode	2312 mode
EBLOne	Not used	$V \geq 3.3$	Not used	Not used
EBL512 G3	Not used	$V \geq 2.10$	Not used	Not used

(V = Software version)

## 9. ACCESSORIES AND SPARE PARTS

### 9.1. BATTERY CONNECTOR

NiMh 1.2V battery and connector.  
Battery for MX series 1h

Art. No. 910002



NiMh 2.4V battery and connector  
BK-220SCHU pack  
Battery for MX IP65 Exit / Emergency light and MX Outdoor

Art. No. 910007



NiMh 2.4V battery and connector  
HHR-210AH pack  
Battery for MX series 3h

Art. No. 910008



### 9.2. RECESS MOUNTING FRAME

Recess mounting frame for easy and quick installation in environments where aesthetics are of importance, such as hotels and office buildings. The recess mounting frame is mounted in the ceiling with springs.

Art. No. 920007 (MXLight)

- Fits a ceiling thickness of between 5 and 25 mm.
- Ø 120 mm ceiling cut-out size



Art. No.920001 (MX25)

- Fits a ceiling thickness of between 5 and 30 mm.
- 287 x 105 mm ceiling cut-out size



### 9.3. BALL PROTECTION

Ball protection are used in for example sports halls, gyms, and stadiums, to protect the exit lights against balls. The ball protection is available in two sizes.

Art. No. 920009 (MX25)

280 x 280 x 100 mm

Art. No. 920010 (MX40)

425 x 425 x 100 mm



## 9.4. TREADED ROD PLATE

Threaded rod plate for ceiling and wall mounting, are used in for example a store that does not have a suspended ceiling. The threaded rod plate allows you to hang the exit and emergency light from your ceiling or wall at any distance.

Mount the analog base on the threaded rod plate. Use a threaded rod ( $\varnothing$  8 mm) of desired length and mount the threaded rod plate with the analog base in one end and another threaded rod plate in the other end.

Art. No. 920013



## 10. MOUNTING

### 10.1. ANALOG BASE

The analog base 3312FLW / 3312W used with MX units can be mounted on the ceiling or on the wall.

### 10.2. MOUNTING OF PICTOGRAM

1. Mount the pictogram by sliding it into the mounting profile according to the picture below. You will hear a click when the pictogram is in right place.
2. Tighten the screw to secure the pictogram.





## 10.4. RED X MODEL

The red cross panel for MX25 and MX40 red x model is installed after installing the pictogram to the mounting profile.

*The red x model is only available as single-sided pictogram.*

1. Slide the red cross panel on top of the exit light pictogram.
2. Tighten the screw.
3. Fix the red cross panel in place with the included plastic buttons.



## 10.5. MX OUTDOOR

The MX Outdoor Emergency Light must be mounted at a maximum height of 7.5 meters, on the wall or on the roof.

1. Mount the metal profile on the wall or in the ceiling, mounting height 2 to 7.5 meter.
2. Mount the luminaire on the metal profile. Press both sides to make tight after the luminaire is mounted on the profile.

*Take in consideration the luminaire angle.*



3. Mount the electronic box.
4. Connect the luminaire cable.

## 10.6. MX IP65 EXIT / EMERGENCY LIGHT

### MOUNT THE HOUSING

1. Remove the two screws and the cover.
2. Use a screw driver to remove the middle part.

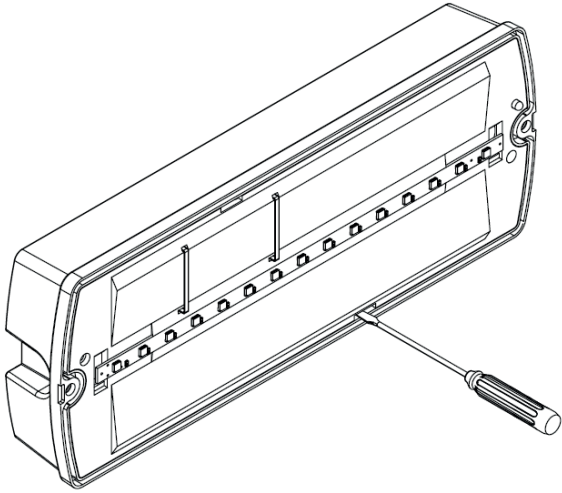

3. Mount the housing on the wall or in the ceiling.

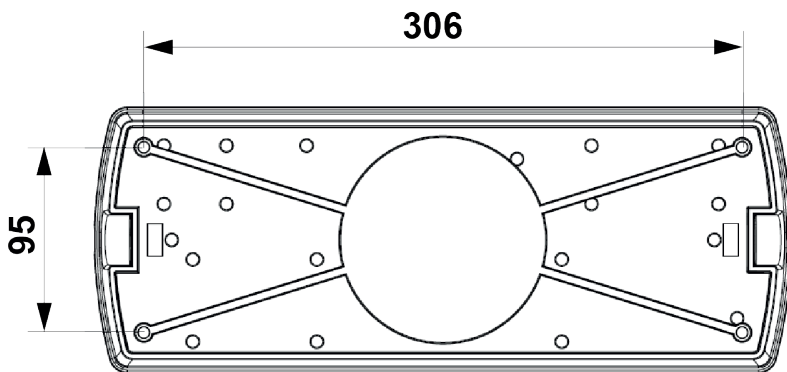

### CABLE CONNECTIONS

4. Make a hole in the housing and insert the cable gland.
5. Pull the cables through the cable glands.

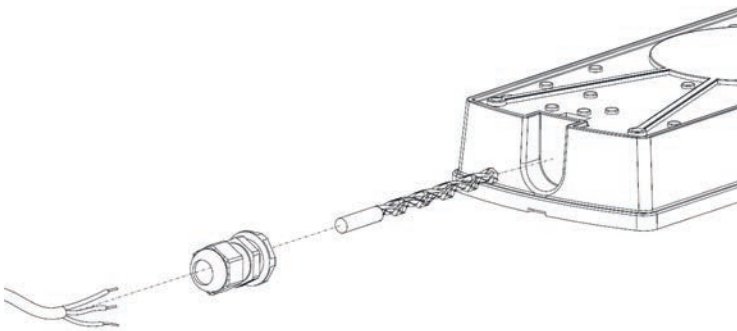

6. Connect the battery cable.

7. Connect the COM loop wires to connectors SA and SB.
8. Connect operating voltage to connectors E+ and E-.
9. Select Exit or Emergency light mode, see chapter [3.6.1. EXIT OR EMERGENCY LIGHT MODE](#) on page 14.
10. Put back the middle part.

#### PLACE THE PICTOGRAM

11. Spray water on the cover / double sided cover.
12. Peel off a piece of the protective plastic and place the pictogram on the cover.
13. Continue to peel off the protective plastic one piece at a time and use the hand to press it in place.
14. Use a straight edged tool such as a credit card to press out all the water and small bubbles.

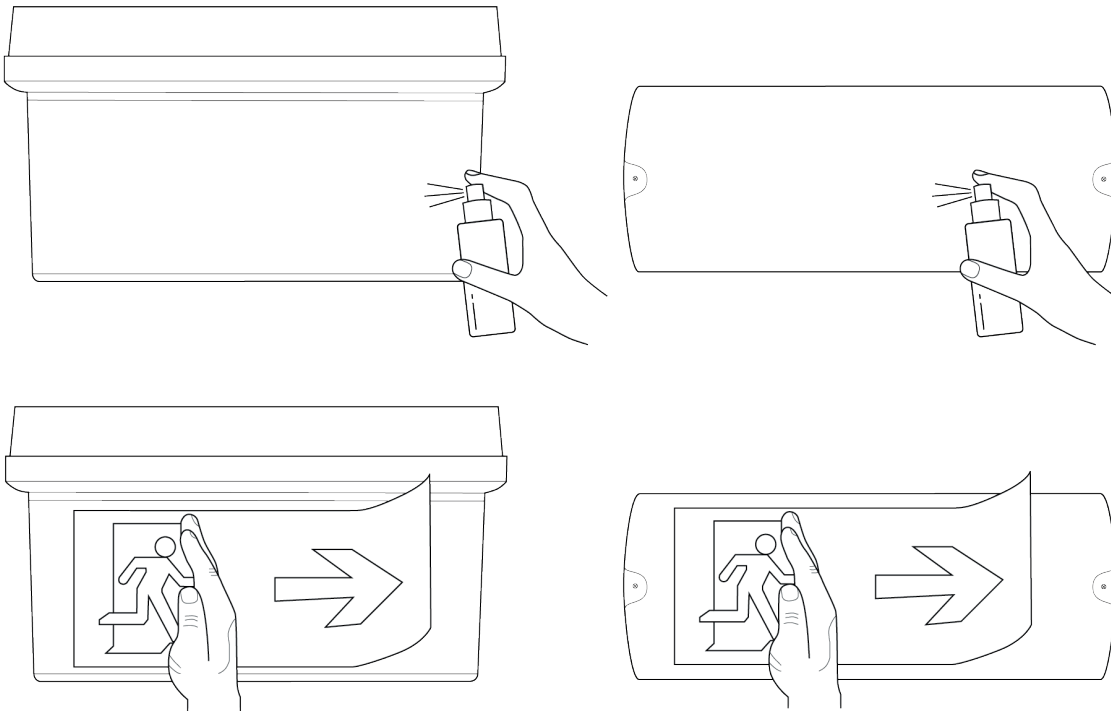

15. Mount the cover / double sided cover on the housing with the two screws.

## 10.7. MX POWER BOX

MX Power box must be mounted on the wall.

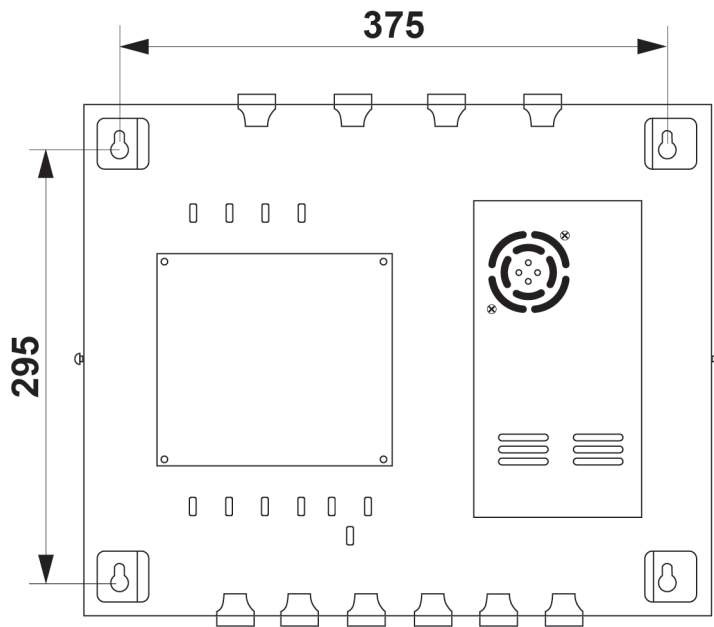

(Measures in mm)

## 10.8. SUPPLY LINE LENGTH

Up to 35-40 units per supply line is recommended.

	Number of units	Supply line length between system to unit	Supply line length between units	Total supply line length
MX25	25	280 m (2x140)	30 m	1000 m
MX40	23	340 m (140+200 m)	30 m	1000 m
MX IP65	23	340 m (140+200 m)	30 m	1000 m

Example of maximum supply line length.

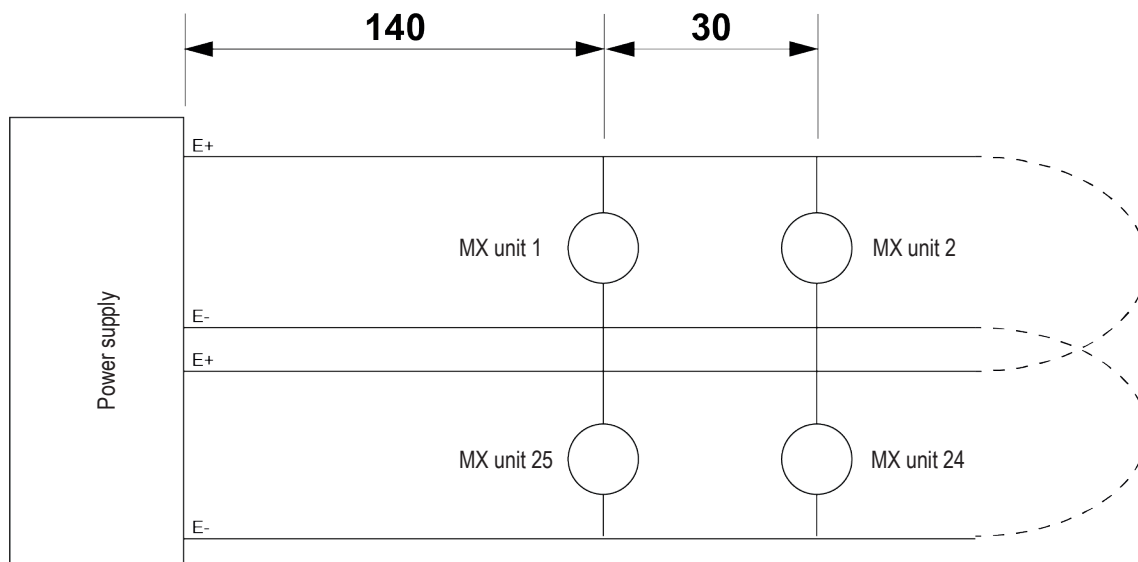

(Measures in meter)

The table below shows calculated examples of maximum supply line length.

If you have a different cable diameter than in the examples, you have to recalculate it yourself with the help of Ohm's law.

Voltage (V) = Current (I) x Resistance (R)

Power (P) = Voltage (V) x Current (I)

*In the calculations it is assumed that the distance from system to units is same as the distance between units.*

Copper wire diameter	Total power consumption of loop units	Minimum supply line voltage	Distance between units and the system to first unit	Maximum supply line length
0.8 mm 1)	40 W (50 pcs. MX25)	31 v	8 m	400 m
1.0 mm 2)	40 W (50 pcs. MX25)	31 v	13 m	650 m
0.8 mm 1)	32 W (40 pcs. MX25)	31 v	12 m	480 m
1.0 mm 2)	32 W (40 pcs. MX25)	31 v	17.5 m	700 m
0.8 mm 1)	24 W (30 pcs. MX25)	31 v	20 m	600 m
1.0 mm 2)	24 W (30 pcs. MX25)	31 v	31.5 m	945 m
0.8 mm 1)	50 W (50 pcs. MX40 / MX IP65)	31 v	5 m	250 m
1.0 mm 2)	50 W (50 pcs. MX40 / MX IP65)	31 v	8 m	400 m
0.8 mm 1)	40 W (40 pcs. MX40 / MX IP65)	31 v	8 m	320 m
1.0 mm 2)	40 W (40 pcs. MX40 / MX IP65)	31 v	11.5 m	460 m
0.8 mm 1)	30 W (30 pcs. MX40 / MX IP65)	31 v	16 m	480 m
1.0 mm 2)	30 W (30 pcs. MX40 / MX IP65)	31 v	24 m	720 m

1) Wire resistance approx. 36.6 Ω/km

2) Wire resistance approx. 24.5 Ω/km

# 11. INSTALLATION AND WIRING

The MX unit is plugged in an analog base 3312FLW / 3312W. The supply line and the COM-loop are connected to the analog base.

**Screen wire termination is not provided.**

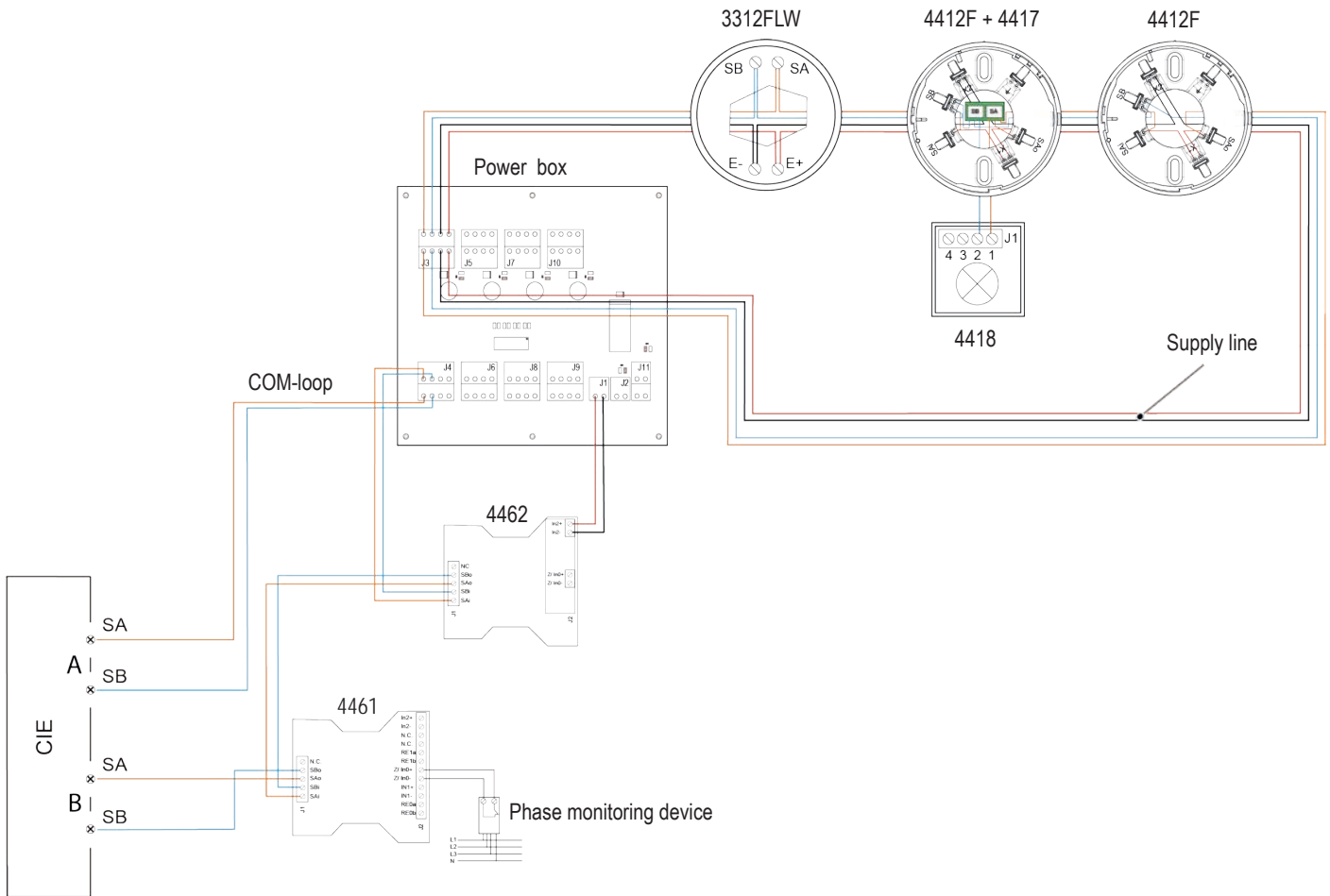

Wire size (Min)	Ø 0.6 mm (0.3 mm <sup>2</sup> )	Ø 0.6 mm (0.28 mm <sup>2</sup> )
Wire size (Max)	Ø 1.6 mm (2 mm <sup>2</sup> )	Ø 1.25 mm (1.2 mm <sup>2</sup> )

## 11.1. WIRING AS EXTENDED

The power box can be used as a supply line extender for operating voltage.  
 Each Power box CONTROL OUT need to be connected to a 4461 / 4462 input.

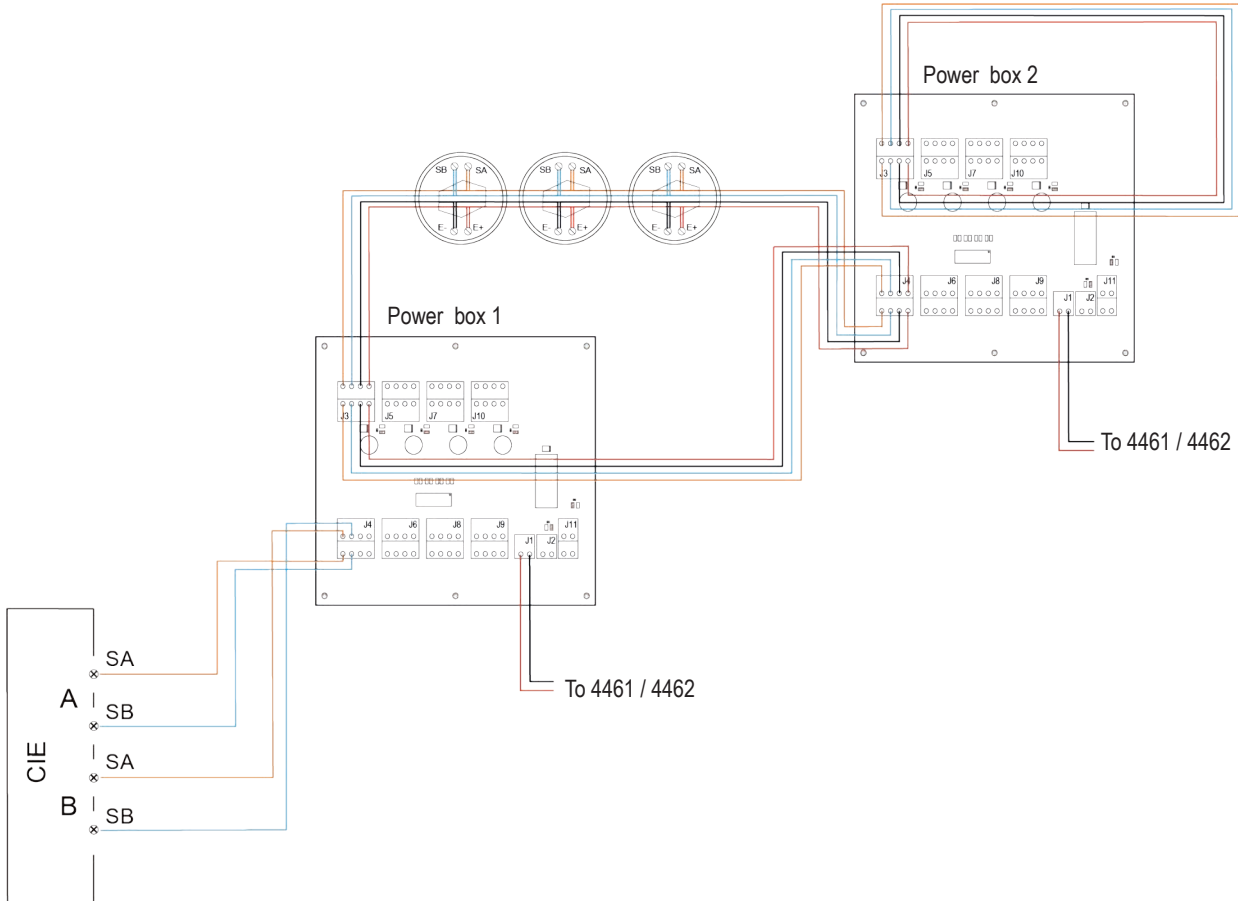

## 11.2. WIRING - DESCRIPTION POWER BOX

On the inside of the power box cover, there is a wiring description. Below we provide an explanation and a simplified description.

### EMEX POWER BOX

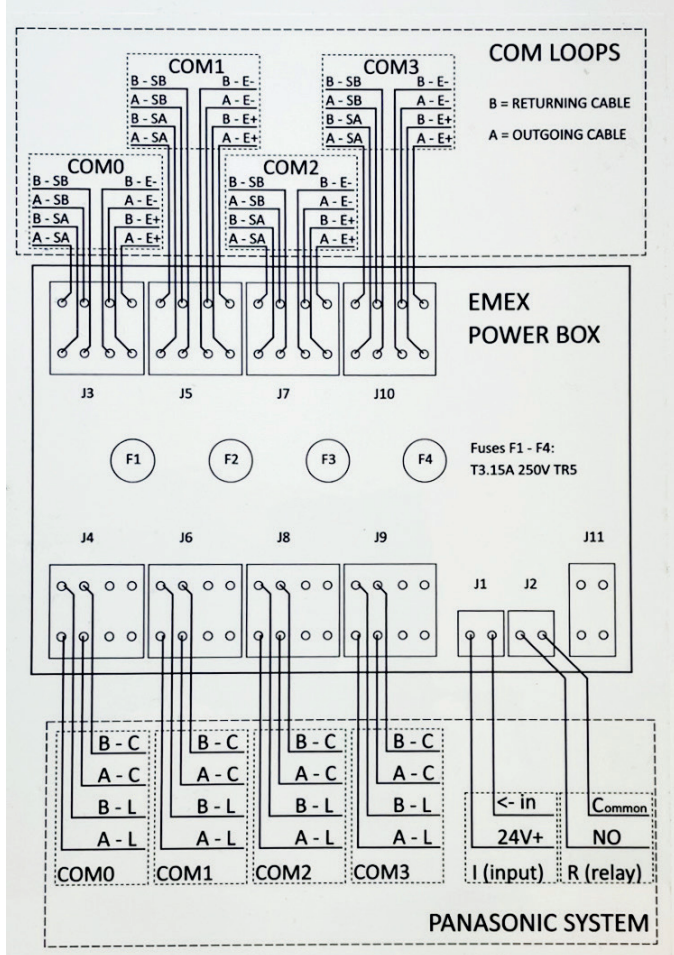

### SIMPLIFIED

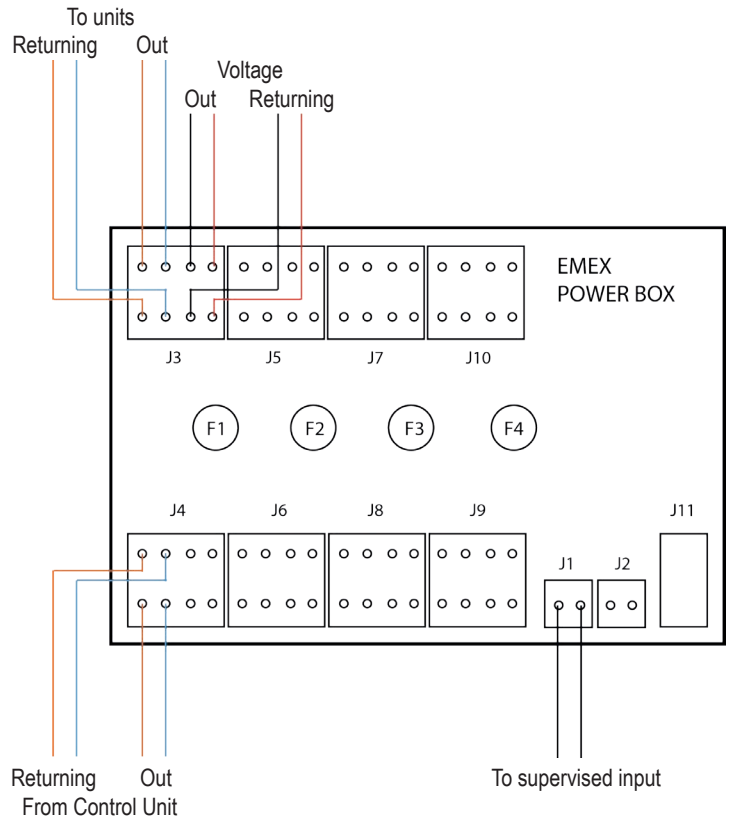

#### From the Panasonic System

- A - L = Outgoing cable SA
- A - C = Outgoing cable SB
- B - L = Returning cable SA
- B - C = Returning cable SB

#### From EMEX power box

- A - SA = Outgoing cable SA
- A - SB = Outgoing cable SB
- B - SA = Returning cable SA
- B - SB = Returning cable SB

#### Voltage

- A - E- = Outgoing cable E-
- A - E+ = Outgoing cable E+
- B - E- = Returning cable E-
- B - E+ = Returning cable E+

## 12. TECHNICAL DATA

*All current consumptions are valid by nominal voltage and by 25 °C.*

MX25 and MX40	
Voltage: Allowed Normal	12 – 32.0 V DC 24V DC
Current:	See "12.1. OPERATING CONDITIONS" on page 49 and 49
COM loop Voltage: Allowed Normal	12 - 30V DC 24V DC
COM loop Current: Quiescent Active:	1,9 mA 1,5 mA
Power consumption when charging:	See "12.1. OPERATING CONDITIONS" on page 49 and 49
Operating time in emergency mode: MX25 MX40	1 h / 3h 1 h / 3h
Address range	001-253
Address setting	With address setting tool
Short circuit isolator	No
Internal battery	Yes
Material	PC polycarbonate
Ambient temperature: Operating Storage	0 to +55 °C 0 to +55 °C
Ambient humidity	Maximum 95 % RH (Non condensing)
Ingress protection rating	IP41
Size: H x W x D MX25 MX40	102 x 261 x 225 mm 102 x 411 x 300 mm
Weight (including batteries): MX25 MX40	1h 390 g / 3h 411 g 1h 705 g / 3h 721 g
Colour	White

MX Light	
Voltage: Allowed Normal	12 – 32.0 V DC 24V DC
Current:	See "12.1. OPERATING CONDITIONS" on page 49 and 49
COM loop Voltage: Allowed Normal	12 - 30V DC 24V DC
COM loop Current: Quiescent Active	1.5 mA 2.9 mA
Power consumption when charging:	See "12.1. OPERATING CONDITIONS" on page 49 and 49
Operating time in emergency mode: MX Light	1 h / 3h
Address range	001-253
Address setting	With address setting tool
Short circuit isolator	No
Internal battery	Yes
Material	PC polycarbonate
Ambient temperature: Operating Storage	0 to +55 °C 0 to +55 °C
Ambient humidity	Maximum 95 % RH (Non condensing)
Ingress protection rating	IP41
Size: H x W x D	102 x 102 x 55-61 mm
Weight (including batteries):	1h 136 g / 3h 151 g
Colour	White

MX OUTDOOR	
Voltage: Allowed Normal	12 – 32.0 V DC 24V DC
Current:	See "12.1. OPERATING CONDITIONS" on page 49 and 49
COM loop Voltage: Allowed Normal	12 - 30V DC 24V DC
COM loop Current: Quiescent Active	1.5 mA 2.9 mA
Power consumption when charging (3h back-up):	See "12.1. OPERATING CONDITIONS" on page 49 and 49
Operating time in emergency mode: MX IP65	3 h
Address range	001-253
Address setting	With address setting tool
Short circuit isolator	No
Internal battery	Yes
Material	PC polycarbonate
Ambient temperature: Operating: MX IP65 Outdoor luminaire MX IP65 electronic box  Storage	-30 to +45 °C -20 to +45 °C  0 to +45 °C
Ambient humidity	Maximum 95 % RH (Non condensing)
Ingress protection rating	IP65
Size: H x W x D MX IP65 Outdoor luminaire MX IP65 electronic box	72 x 45 x 50 mm 104 x 104 x 48 mm
Weight (including batteries): MX IP65 Outdoor luminaire MX IP65 electronic box	159 g 242 g
Colour	White

MX IP65 Exit / Emergency light	
Voltage: Allowed Normal	12 – 32.0 V DC 24V DC
Current (3h back-up):	See "12.1. OPERATING CONDITIONS" on page 49 and 49
COM loop Voltage: Allowed Normal	12 - 30V DC 24V DC
COM loop Current: Exit light, Quiescent Exit light, Active Emergency light, Quiescent Emergency light, Active	1,9 mA 1,5 mA 1.5 mA 2.9 mA
Power consumption when charging (3h back-up):	See "12.1. OPERATING CONDITIONS" on page 49 and 49
Operating time in emergency mode: MX IP65 Exit MX IP65 Emergency	3 h 3 h
Address range	001-253
Address setting	With address setting tool
Short circuit isolator	No
Internal battery	Yes
Material	PC polycarbonate
Ambient temperature: Operating Storage	-20 to +45 °C 0 to +45 °C
Ambient humidity	Maximum 95 % RH (Non condensing)
Ingress protection rating	IP65
Size: H x W x D MX IP65	79 x 136 x 356 mm
Weight (including batteries): MX IP65	930 g
Colour	White

## 12.1. OPERATING CONDITIONS

### 12.1.1. 1h back-up battery

25M-Mode 1h			
Status	Voltage	Current	Power
Normal mode, Battery charging	24V	34 mA	0,8 W
Normal mode, Battery full	24V	16 mA	0,4 W
RED-X on, Charging battery	24V	48 mA	1,2 W
RED-X on, Battery full	24V	28 mA	0,7 W
Fault mode, No battery, No LED.	24V	8 mA	0,2 W

40M-Mode 1h			
Status	Voltage	Current	Power
Normal mode, Battery charging	24V	46 mA	1,1 W
Normal mode, Battery full	24V	29 mA	0,7 W
RED-X on, Charging battery	24V	48 mA	1,2 W
RED-X on, Battery full	24V	31 mA	0,7 W
Fault mode, No battery, No LED.	24V	8 mA	0,2 W

EMERGENCY-Mode 1h			
Status	Voltage	Current	Power
Normal mode, Battery charging	24V	26 mA	0,6 W
Normal mode, Battery full	24V	8 mA	0,2 W
External control	24V	1mA	0,0 W
Fault mode, No battery, No LED.	24V	8 mA	0,2 W

## 12.1.2. 3h back-up battery

25M-Mode 3h			
Status	Voltage	Current	Power
Normal mode, Battery charging	24V	38 mA	0,9 W
Normal mode, Battery full	24V	16 mA	0,4 W
RED-X on, Charging battery	24V	52 mA	1,2 W
RED-X on, Battery full	24V	29 mA	0,7 W
Fault mode, No battery, No LED.	24V	8 mA	0,2 W

40M-Mode 3h			
Status	Voltage	Current	Power
Normal mode, Battery charging	24V	50 mA	1,2 W
Normal mode, Battery full	24V	28 mA	0,7 W
RED-X on, Charging battery	24V	52 mA	1,2 W
RED-X on, Battery full	24V	31 mA	0,7 W
Fault mode, No battery, No LED.	24V	8 mA	0,2 W

EMERGENCY-Mode 3h			
Status	Voltage	Current	Power
Normal mode, Battery charging	24V	30 mA	0,7 W
Normal mode, Battery full	24V	8 mA	0,2 W
External control	24V	1 mA	0,0W
Fault mode, No battery, No LED.	24V	8 mA	0,2 W

### Comments

The measurements are made with one device. There may be minor differences between the devices, and in addition, the line voltage directly affects the current drawn by the device. The line voltage also affects the efficiency of the device, so the power taken up by the device also changes in relation to the line voltage. However, this is quite minor.

## 13. APPROVALS

Applicable directive/ Approval	Applicable standards	Notified body
EMC	EN 55014-1 (Emission) EN 55014-2 (Immunity)	Declaration made by manufacturer (Emex)
LVD	EN 60335-2 EN 60334-2	
RoHS	EN IEC 63000	



---

DOCUMENT NAME: TECHNICAL DESCRIPTION MX25, MX40, MX Light, and MX IP65  
DOCUMENT NUMBER: MEW02732 EN  
DATE OF ISSUE: 2021-06-18  
REV:8  
DATE OF REVISION: 2026-04-23

Panasonic Fire & Security Europe AB  
Jungmansgatan 12  
SE-211 11 Malmö  
SE  
Tel: +46 (0)40 697 70 00